

Avery Dennison
Label and Packaging Materials

Product Component Guide

2024 ANZ



Contents

How to use this guide	3
Index	
Facestock	5
Adhesive	11
Liner	14
Adhesive - Plastic Substrate Guide	117
Packaging Recyclability	118
Designing for Recyclability	122
Important information	125
Product Selection Considerations	127

How to use this guide

Facestock

Basis Weight

The average weight of the facestock in grams per square meter of material.

Thickness

The thickness of the facestock in microns.

Adhesive

Initial Tack

Defines the degree to which the product adheres to the substrate on first contact.

Ultimate Adhesion

Identifies the long-term adhesive strength.

Minimum Application Temperature

The minimum temperature at the time of application of the label. The substrate must be clean at the time of application.

Service Temperature Range

The range of temperatures within which the properties of the applied label are substantially unchanged over a prolonged period of time. The actual duration and temperature extremes depend also on the type of face material used, the substrate and environment.

Applications

Freezer

Adhesives suitable for application to substrates at temperatures down to -20°C

Chilled

Suitable for use on dry surfaces that may be exposed to condensation after application.

Wet Surfaces

Suitable for use on surfaces where partially exposed to limited moisture or condensation.

Tight Mandrel

Suitable for low diameter substrates greater than 15mm on glass and PE. Prior testing is highly recommended.

Ice Bucket

Suitable for submersion in ice bucket for periods of up to 2 hours.

Liner

Basis Weight

The average weight of the liner in grams per square meter of material.

Thickness

The thickness of the facestock in microns.

Sustainable ADvantage

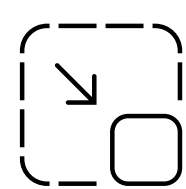

Reduction in the Use of Materials
Use only what is necessary

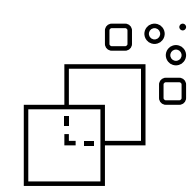

Enables Recyclability, Reuse, or Compostability
What we use can be used again

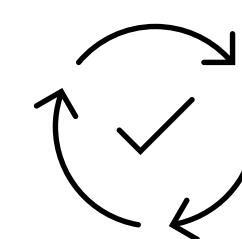

Contains Recycled or Renewable Content
Give a second life to what has already been used

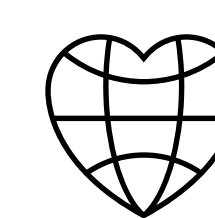

Responsibly Sourced Products
Products sourced from a supply chain that shows care for people and the environment

Facestock

Prime Paper	Basis Weight (g/m ²)	Thickness (µm)	Conventional Print	VI	Printability	Print Definition	Print Durability	Stiffness	Conformability	OBA	Tensile Strength	Water Resistance	Wet Opacity	Dry Opacity
Cast Coated														
High Gloss White FSC	80	84	✓	T	●●●●●	●●●●●	●●●●●	●●●●●	●	✓	●●●●●	●●●●●	●●●●	●●●●●
HGW Premium FSC	80	78	✓	T	●●●●●	●●●●●	●●●●●	●●●●●	●	✓	●●●●●	●●●●●	●●●●	●●●●●
Machine Coated														
Gloss Plus FSC	80	65	✓	✓	●●●●●	●●●●●	●●●●●	●●●	●●	✓	●●●●	●●●●	●●●●	●●●●
MC Primecoat 80 FSC	80	69	✓	✓	●●●●●	●●●●●	●●●●●	●●●	●●	✓	●●●●	●●●●	●●●	●●●●
MC Primecoat 70 FSC	70	61	✓	✓	●●●●●	●●●●●	●●●●●	●●●	●●	✓	●●●●	●●●●	●●●	●●●●
Light Weight														
LW60 FSC	62	55	✓	T	●●●	●●●	●●●	●	●●●●●	✓	●	●●●	●	●●
Vellum														
Super Vellum FSC	70	66	✓	T	●●●	●●●	●●●	●●●●	●●	✓	●●	-	●●●	●●●●
Vellum Extra	73	71	✓	T	●●●	●●●	●●●	●●●●	●		●●	-	●●●	●●●
Specialty Prime Paper														
Radiant Paper FSC	78	73	✓	T	●●●	●●●	●●●	●●●●	●		●●	-	●●●	●●●
Tyre Plus	81	64	✓	T	●●●●	●●●●	●●●●	●●●●●	●●		●●	-	●●●●●	●●●●●
MC90 OPQ FSC	100	85	✓	T	●●●●●	●●●●●	●●●●●	●●●●●	●	✓	●●●	●●●	●●●●●	●●●●●

T – Test first

Prime Film

	Basis Weight (g/m ²)	Thickness (µm)	Conventional Print	VI	Printability	Print Definition	Print Durability	Stiffness	Conformability
Conformable Films									
<u>Primax® Plus</u>	75	76	✓	T	●●●●●	●●●●●	●●●●●	●●●●	●●●●●
<u>Primax® I</u>	101	88	✓	T	●●●●●	●●●●●	●●●●●	●●●●●	●●●●
<u>GCX White</u>	64	63	✓	T	●●●	●●●	●●●	●●	●●●●
<u>GCX Clear</u>	61	63	✓	T	●●●	●●●	●●●	●●	●●●●
<u>Polyexact White</u>	82	82	✓	T	●●●●●	●●●●●	●●●●●	●●	●●●●●
<u>Polyexact Clear</u>	78	83	✓	T	●●●●●	●●●●●	●●●●●	●●	●●●●●
<u>Flex+ White NTC</u>	50	55	✓	T	●●●	●●●	●●●	●●	●●●●
<u>Flex+ Clear NTC</u>	50	55	✓	T	●●●	●●●	●●●	●●	●●●●
Rigid White Films									
<u>rPP TC WHITE</u>	42	65	✓	T	●●●●●	●●●●●	●●●●	●●●●	●●
<u>PP60 White NTC</u>	39	56	✓	T	●●●●	●●●●	●●●	●●●	●●
<u>Opalux 80 NTC</u>	55	75	✓	T	●●●●	●●●●	●●●	●●●●●	●
<u>Pearlux 80 NTC</u>	55	75	✓	T	●●●●	●●●●	●●●	●●●●●	●
<u>PP60 Top Pearlized White</u>	45	60	✓	T	●●●●●	●●●●●	●●●●●	●●●●	●●●●

T – Test first

Prime Film

	Basis Weight (g/m ²)	Thickness (µm)	Conventional Print	VI	Printability	Print Definition	Print Durability	Stiffness	Conformability
Rigid Clear Films									
<u>PP40 TC Clear</u>	37	40	✓	-	●●●●●	●●●●●	●●●●	●●	●●●
<u>PP50 TC Clear</u>	47	50	✓	-	●●●●●	●●●●●	●●●●	●●●●	●●
<u>PP OLF-20</u>	18	20	✓	-	●	●	●	●	●
Vinyl (PVC) / Metalised BOPP / Digital Films									
<u>PVC White</u>	112	84	✓	T	●●●	●●●	●●●●	●●●	●●●●
<u>PP50 TC Silver</u>	46	50	✓	T	●●●●	●●●●	●●●●	●●	●●●
<u>PP80 White Dig TC</u>	62	80	Digital	T	●●●●●	●●●●●	●●●●●	●●●●●	●

T – Test first

VI Paper

	Basis Weight (g/m ²)	Thickness (µm)	Conventional Print	VI	Printability	Print Definition	Print Durability	Stiffness	Conformability	OBA	Tensile Strength	Water Resistance	Wet Opacity	Dry Opacity
EDP Paper														
Zig Zag FSC	68	66	✓	✓	●●●	●●●	●●●	●●●●	●		●●●			
Direct Thermal														
Direct Thermal 200HD FSC	78	81	✓	✓	●●●●●	●●●●●	●●●●●	●●●●	●●	✓	●●●●●	●●●●●	●●●●●	●●●●●
DT150RL FSC	73	74	✓	✓	●●●●●	●●●●●	●●●●	●●●●	●●	✓	●●●●●	●●●●	●●●●●	●●●●●
rDT300LD BPAF FSC	70	75	✓	✓	●●●●	●●●●	●●●	●●●●	●●		●●●●●	●●	●●	●●●●●
DT60 TC	60	60	✓	✓	●●●●●	●●●●●	●●●●	●●●●	●●	✓	●●●●●	●●●●	●●●●●	●●●●●
Direct Thermal Linerless														
Premium Therm TC25 Linerless	78	81		✓	●●●●●	●●●●●	●●●	●●●●●	●●		●●●●●	●●●●●	●●●●●	●●●●●
Thermal Transfer														
TT Elite FSC	75	74	✓	✓	●●●●●	●●●●●	●●●●●	●●●	●	✓	●●●●●	●●●●●	●●●●●	●●●●●
Laser/Inkjet Paper														
LCJ Premium	64	72	✓	✓	●●●●●	●●●●●	●●●	●●●	●		●●			
LCJ Premium FSC	64	75	✓	✓	●●●●●	●●●●●	●●●	●●●	●		●●			
Laserpro FSC	70	80	✓	✓	●●●●	●●●	●●●	●●●	●		●●			
Gloss IJ Paper FSC	88	106	✓	✓	●●●●●	●●●●●	●●●●●	●●●●●	●		●●●			

T – Test first

VI Film

	Basis Weight (g/m ²)	Thickness (µm)	Conventional Print	VI	Printability	Print Definition	Print Durability	Stiffness	Conformability	OBA	Tensile Strength	Water Resistance	Wet Opacity	Dry Opacity
Direct Thermal														
<u>DT300N</u>	70	85	T	✓		●●●●●	●●●●●	●●●●	●					
<u>Polythermal Plus</u>	68	83	✓	✓	●●●●●	●●●●●	●●●●●	●●●●	●					
Thermal Transfer														
<u>Synthetic Paper</u>	68	75	✓	✓	●●●●●	●●●●●	●●●●	●●●●●	●●					
<u>Data PE 80</u>	75	95	✓	✓	●●●●●	●●●●●	●●●●●	●●	●●●●●					
<u>2M PET Range</u>	75	50	✓	✓	●●●●●	●●●●●	●●●●	●●●●●	●●					
Laser/Inkjet Film														
<u>Dataflex</u>	109	178	✓	✓	●●●●●	●●●●●	●●●●●	●●●●	●●●●					
<u>100um IJ SYN Paper</u>	69	100	✓	✓	●●●●●	●●●●	●●●●	●●●●	●●●●					

T – Test first

Wine

	Basis Weight (g/m ²)	Thickness (µm)	Conventional Print	VI	Printability	Print Definition	Print Durability	Stiffness	Conformability	OBA	Tensile Strength	Water Resistance	Wet Opacity	Dry Opacity
Cast Coated														
<u>Cast Gloss Elite FSC</u>	80	84	✓	T	●●●●●	●●●●●	●●●●●	●●●●●	●	✓	●●●●●	●●●●●	●●●●	●●●●●
Uncoated Paper														
<u>Super White Opaque FSC</u>	110	130	✓	-	●●●●	●●●●	●●●●	●●●●	●●				●●●●●	●●●●●
<u>Estate #8 PE FSC</u>	114	140	✓	-	●●●●	●●●●	●●●●	●●●●	●●	✓			●●●●	●●●●●
<u>Estate #4 PE FSC</u>	109	139	✓	-	●●●●	●●●●	●●●●	●●●●	●●				●●●●	●●●●●
<u>Vintage FSC</u>	110	130	✓	-	●●●●	●●●●	●●●●	●●●●	●●				●●●●●	●●●●●
Metalized Paper														
<u>Maxflex Bright Silver FSC</u>	83	66	✓	-	●●●●	●●●●	●●●●	●●●	●●				-	-
Specialty Paper														
<u>Frozen Orion Diamond V2 Plus FSC</u>	110	120	✓	-	●●●●●	●●●●●	●●●●●	●●●●●	●				●●●●	●●●●
<u>Artisan rPLUS FSC</u>	124	156	✓	-	●●●●	●●●●	●●●●	●●●●	●●	✓			●●●●●	●●●●●
<u>Artisan FSC</u>	95	135	✓	-	●●●●	●●●●	●●●●	●●●●	●●	✓			●●●●	●●●●●
<u>ARCTIC rPLUS FSC</u>	125	155	✓	-	●●●●	●●●●	●●●●	●●●●	●●				●●●●	●●●●●

T – Test first

Permanent

Special Purpose

		Facestock	Initial Tack	Ultimate Adhesion	Min. App. Temp	Service Temp.	Applications					Substrates							Food Compliance				
							Freezer	Chilled	Wet Surfaces	Tight Mandrel	Ice Bucket	Cardboard	PET	HDPE	LDPE	PP	Glass	PVC	Rigid PS	Indirect	Direct		
<u>C2075</u>	Rubber Based Hotmelt	Paper/Film	High	High	-20°C	-50°C to 70°C	✓	✓	T	-	-	✓	✓	✓	✓	✓	✓	✓	✓	✓	✓	✓	✓
<u>CD303</u>	Emulsion Acrylic	Film	Very High	Very High	0°C	-30°C to 70°C	-	✓	✓	-	-	✓	✓	✓	✓	✓	✓	✓	✓	✓	✓	✓	-
<u>S2012HT</u>	Emulsion Acrylic	Paper	High	High	0°C	-20°C to 80°C	-	-	-	-	-	T	✓	T	T	T	T	✓	T	✓	✓	-	
<u>S2660</u>	Emulsion Acrylic	Paper	High	Very High	5°C	-20°C to 80°C	-	-	-	T	-	-	✓	✓	✓	✓	✓	✓	✓	✓	✓	-	
<u>S333</u>	Emulsion Acrylic	Film	High	High	-4°C	-40°C to 148°C	-	✓	-	✓	-	-	✓	✓	✓	✓	✓	✓	✓	✓	✓	-	
<u>S7400</u>	Emulsion Acrylic	Film	Medium	High	-4°C	-40°C to 80°C	-	✓	✓	✓	✓	✓	✓	✓	✓	✓	✓	-	✓	✓	✓	-	
<u>SPX</u>	Rubber Based Hotmelt	Film	Very High	Very High	-5°C	-40°C to 70°C	-	✓	-	✓	-	✓	✓	✓	✓	✓	✓	-	✓	✓	✓	-	
<u>TS79</u>	Rubber Based Hotmelt	Paper/Film	Very High	Very High	0°C	-20°C to 70°C	-	T	-	T	-	✓	✓	✓	T	✓	✓	✓	✓	✓	✓	-	
<u>AT20</u>	Emulsion Acrylic	Paper	Medium	Medium	-40°C	-50°C to 90°C	T	✓	✓	✓	✓	✓	✓	✓	✓	✓	✓	✓	✓	✓	✓	-	
Wine																							
<u>rS2030MB</u>	Emulsion Acrylic	Paper	Very High	Very High	5°C	-20°C to 80°C	-	✓	T	✓	✓	T	✓	✓	✓	✓	✓	-	✓	✓	✓	-	
<u>S2047</u>	Rubber Based Hotmelt	Paper	Very High	Very High	0°C	-40°C to 70°C	-	✓	✓	✓	✓	✓	✓	✓	✓	✓	✓	✓	✓	✓	✓	✓	
<u>S3037</u>	Rubber Based Hotmelt	Paper	Very High	Very High	0°C	-40°C to 70°C	-	✓	T	✓	✓	✓	✓	✓	✓	✓	✓	✓	✓	✓	✓	✓	
<u>WLK202</u>	Emulsion Acrylic	Paper	Very High	Very High	0°C	-30°C to 80°C	-	✓	T	✓	✓	✓	✓	✓	✓	✓	✓	-	✓	✓	✓	-	
<u>Z1010</u>	Emulsion Acrylic	Paper	High	Very High	5°C	-20°C to 60°C	-	✓	✓	T	✓	T	✓	✓	✓	✓	✓	-	✓	✓	✓	-	

T - Test substrate first

Removable

		Facestock	Initial Tack	Ultimate Adhesion	Min. App. Temp	Service Temp.	Applications					Substrates							Food Compliance		
							Freezer	Chilled	Wet Surfaces	Tight Mandrel	Ice Bucket	Cardboard	PET	HDPE	LDPE	PP	Glass	PVC	Rigid PS	Indirect	Direct
<u>R100</u>	Rubber Based Solvent	Paper	Medium	Medium	- 20°C	-40°C to 80°C	T	✓	-	-	-	✓	✓	✓	✓	✓	✓	-	-	-	-
<u>R5000</u>	Emulsion Acrylic	Paper/Film	Low	Medium	- 5°C	-30°C to 80°C	-	T	-	-	-	✓	-	✓	✓	✓	✓	-	✓	✓	✓
<u>SR2</u>	Emulsion Acrylic	Film	Medium	Medium	- 5°C	-30°C to 60°C	T	✓	-	-	-	-	-	✓	✓	✓	✓	-	-	-	-
<u>UVR145</u>	Emulsion Acrylic	Film	Medium	Medium	5°C	-20°C to 80°C	-	✓	-	-	-	✓	✓	✓	✓	✓	✓	T	-	-	-
<u>LR2N</u>	Emulsion Acrylic	Paper	Low	Low	-15°C	-30°C to 80°C	T	T	-	-	-	-	✓	✓	-	✓	✓	-	✓	-	-

T - Test substrate first

Liner

	Basis Weight (g/m ²)	Thickness (μm)
Glassine		
<u>BG33 WH N</u>	50	45
<u>BG40 BR</u>	62	56
<u>BG40 WH N</u>	59	53
<u>BG40 WH NF</u>	59	53
<u>BG45 WH</u>	72	63
PET		
<u>PET23 = 0.92M PET</u>	35	23
<u>PET30 = 1.2M PET</u>	42	30
<u>rPET23</u>	33	23
<u>rPET30</u>	43	30
Kraft		
<u>B100</u>	100	81
<u>CCK</u>	58	55
<u>50 SCK</u>	88	81
<u>HF55N</u>	58	55
<u>HF75</u>	76	76
<u>HF80N</u>	81	86

High Gloss White FSC

A white, one side cast coated, gloss finished, wood-free printing paper

Applications

Cosmetics, pharmaceutical, food, beverage, wine & promotional labels

Features

- FSC Certified
- High gloss coating giving brilliant multicolour print quality and attractive gloss appearance
- Good resistance to edge wicking where some contact with water may occur
- Good scuff and environmental resistance when offered with a suitable varnish, but is not suitable for outdoor use
- High exposure to moisture may cause product to exhibit edge-wicking

Printing & Converting

- Printable using all conventional label printing technologies, including foil stamping
- Suitable for conventional die-cutting processes and conventional inks & varnishes; consult your ink specialist for details
- Can be embossed and/or hot foil stamped
- Over-laminating film helps improve scuff and moisture resistance

Basis Weight
80 g/m²

Thickness
84 µm

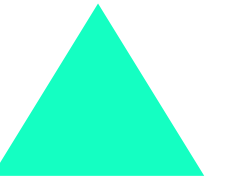

Print Technology

Conventional Press
✓

VI
Test

Print Performance

Printability
●●●●●

Stiffness
●●●●●

Print Definition
●●●●●

Conformability
●○○○○

Print Durability
●●●●●

OBA
✓

Tensile Strength
●●●●●

Wet Opacity
●●●●○

Water Resistance
●●●●●

Dry Opacity
●●●●●

HGW Premium FSC

A white, one side cast coated, gloss finished, wood-free printing paper

Applications

Cosmetics, pharmaceutical, food, beverage, wine & promotional labels

Features

- FSC Certified
- High gloss coating giving brilliant multicolour print quality and attractive gloss appearance
- Good resistance to edge wicking where some contact with water may occur
- Good scuff and environmental resistance when offered with a suitable varnish, but is not suitable for outdoor use
- High exposure to moisture may cause product to exhibit edge-wicking

Printing & Converting

- Printable using all conventional label printing technologies, including foil stamping
- Suitable for conventional die-cutting processes and conventional inks & varnishes; consult your ink specialist for details
- Over-laminating film helps improve scuff and moisture resistance

Basis Weight
80 g/m²

Thickness
78 µm

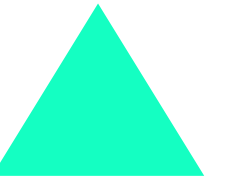

Print Technology

Conventional Press
✓

VI
Test

Print Performance

Printability
●●●●●

Stiffness
●●●●●

Print Definition
●●●●●

Conformability
●○○○○

Print Durability
●●●●●

OBA
✓

Tensile Strength
●●●●●

Wet Opacity
●●●●○

Water Resistance
●●●●●

Dry Opacity
●●●●●

Gloss Plus FSC

An FSC approved white, super gloss finished wood-free printing paper

Applications

Cosmetics, pharmaceutical, food, beverage, wine & promotional labels

Features

- FSC Certified
- Superior gloss coating giving excellent multicolour print quality that can be further improved with a suitable varnish
- Good scuff and environmental resistance when offered with a suitable varnish, but is not suitable for outdoor use
- High exposure to moisture may cause product to exhibit edge-wicking

Printing & Converting

- Printable using all conventional label printing technologies, including foil stamping
- Suitable for conventional die-cutting processes and conventional inks & varnishes; consult your ink specialist for details
- Over-laminating film helps improve scuff and moisture resistance

Basis Weight
80 g/m²

Thickness
65 µm

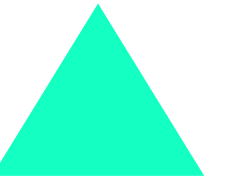

Print Technology

Conventional Press
✓

VI
✓

Print Performance

Printability
●●●●●

Stiffness
●●●●●

Print Definition
●●●●●

Conformability
●●●●●

Print Durability
●●●●●

OBA
✓

Tensile Strength
●●●●●

Wet Opacity
●●●●●

Water Resistance
●●●●●

Dry Opacity
●●●●●

MC Primecoat 80 FSC

A white, one side machine coated, wood-free printing paper, with a semigloss appearance

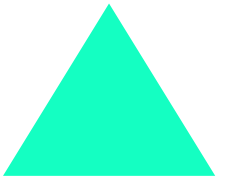

Basis Weight
80 g/m²

Thickness
69 µm

Applications

Cosmetics, pharmaceutical, food, beverage & promotional labels

Features

- FSC Certified
- Excellent gloss appearance and multicolour print quality
- Provides some moisture resistance when paired with a suitable varnish or overlaminating film
- Good scuff and environmental resistance when offered with a suitable varnish, but is not suitable for outdoor use
- High exposure to moisture may cause product to exhibit edge-wicking

Printing & Converting

- Printable by all converting printing technologies including single and/or multicolor, line or process printing by Letterpress, Offset or Flexo
- A higher gloss finish can be achieved by additional varnishing
- Good conversion characteristics in rotary and flatbed presses

Print Technology

Conventional Press
✓

VI
✓

Print Performance

Printability
●●●●●

Stiffness
●●●●●

Print Definition
●●●●●

Conformability
●●●●●

Print Durability
●●●●●

OBA
✓

Tensile Strength
●●●●●

Wet Opacity
●●●●●

Water Resistance
●●●●●

Dry Opacity
●●●●●

MC Primecoat 70 FSC

A white, one side machine coated, wood-free printing paper, with a semigloss appearance

Applications

Cosmetics, pharmaceutical, food, beverage & promotional labels

Features

- FSC Certified
- Excellent gloss appearance and multicolour print quality
- Provides some moisture resistance when paired with a suitable varnish or overlaminating film
- Good scuff and environmental resistance when offered with a suitable varnish, but is not suitable for outdoor use
- High exposure to moisture may cause product to exhibit edge-wicking

Printing & Converting

- Printable by all converting printing technologies including single and/or multicolor, line or process printing by Letterpress, Offset or Flexo
- A higher gloss finish can be achieved by additional varnishing
- Good conversion characteristics in rotary and flatbed presses

Basis Weight
70 g/m²

Thickness
61 µm

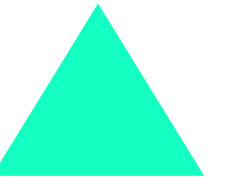

Print Technology

Conventional Press
✓

VI
✓

Print Performance

Printability
●●●●●

Stiffness
●●●○○

Print Definition
●●●●●

Conformability
●●○○○○

Print Durability
●●●●●

OBA
✓

Tensile Strength
●●●●○

Wet Opacity
●●●○○

Water Resistance
●●●○

Dry Opacity
●●●●○

LW60 FSC

A light weight, white, one side machine coated, wood-free printing paper, with a semigloss appearance

Applications

Small cylindrical substrates for pharmaceutical and cosmetic applications, pill bottles and syringes, or security seals

Features

- FSC Certified
- Low memory, making it ideal for tight mandrel applications such as labelling small cylindrical substrates
- Also used for tamper-resistant security labelling due to its easy-tear properties
- Provides excellent functionality for labelling pharmaceuticals in vials, syringes, dropper bottles, etc.

Printing & Converting

- Printable using all conventional label printing technologies, including foil stamping
- Suitable for conventional die-cutting processes, consult your die-consultant for details
- Suitable for conventional inks and varnishes, consult your ink specialist for details

Basis Weight
62 g/m²

Thickness
55 µm

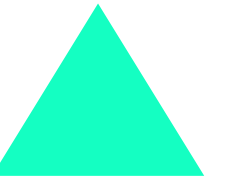

Print Technology

Conventional Press
✓

VI Test

Print Performance

Printability
●●●○○

Stiffness
●○○○○

Print Definition
●●●○○

Conformability
●●●●●

Print Durability
●●●○○

OBA
✓

Tensile Strength
●○○○○

Wet Opacity
●○○○○

Water Resistance
●●●○○

Dry Opacity
●●○○○

Super Vellum FSC

A matt white, wood-free, surface sized and calendered printing paper

Basis Weight
70 g/m²

Thickness
66 µm

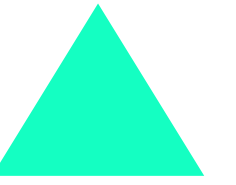

Applications

Retail, food packaging, weight scale, cosmetics, toiletries and promotional labelling

Features

- FSC Certified
- Provides excellent print resolution

Printing & Converting

- Printable using all conventional label printing technologies, including foil stamping, impact and thermal transfer printing
- Suitable for conventional die-cutting processes, consult your die-consultant for details
- Suitable for conventional inks and varnishes, consult your ink specialist for details

Print Technology

Conventional Press
✓

VI Test

Print Performance

Printability
●●●○

Stiffness
●●●●○

Print Definition
●●●○

Conformability
●●○○○

Print Durability
●●●○

OBA
✓

Tensile Strength
●●○○○

Wet Opacity
●●●○

Water Resistance
-

Dry Opacity
●●●○

Vellum Extra

A matte white, wood-free, surface sized and calendered printing paper

Applications

Retail, food packaging, weight scale, cosmetics, toiletries and promotional labelling

Features

- Provides excellent print resolution

Printing & Converting

- The facestock can be printed in single and/or multi-colour line or process printing using letterpress, offset, flexo, screen or hot foil stamping
- Good conversion in rotary and flatbed
- Complex shaped labels may limit the conversion speed

Basis Weight

73 g/m²

Thickness

71 µm

Print Technology

Conventional Press



VI

Test

Print Performance

Printability



Stiffness



Print Definition



Conformability



Print Durability



OBA

Tensile Strength



Wet Opacity



Water Resistance

-

Dry Opacity



Radiant Paper FSC

Wood-free, one side coated, fluorescent papers in yellow, orange, red, green or pink

Applications

Warning, inventory, instruction, promotional, advertising labels and price marking

Features

- FSC Certified
- Excellent printability
- Available in five bold colours
- Suitable for applications requiring fluorescent coloured labels to distinguish between products

Printing & Converting

- Suitable for printing by most conventional press printing such as letterpress, offset and flexo

Basis Weight

78 g/m²

Thickness

73 µm

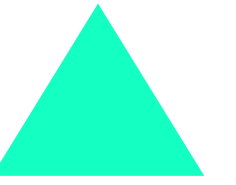

Print Technology

Conventional Press



VI

Test

Print Performance

Printability



Stiffness



Print Definition



Conformability



Print Durability



OBA

-

Tensile Strength



Wet Opacity



Water Resistance

-

Dry Opacity



Tyre Plus

A white semi-gloss, wood-free printing paper laminated to a flexible aluminium barrier foil

Applications

Tyre Labelling

Features

- Designed to meet the specific requirements of labels for rough and open structured substrates such as tyre treads
- Provides excellent anchorage of the label to compound curved & irregular surfaces like tyres
- The aluminium foil barrier prevents migration of components through the facestock, thus avoiding facestock staining

Printing & Converting

- Convertible by both rotary and flatbed however better results are achieved through flatbed converting
- Sharp, high quality dies are required to assure smooth matrix stripping and to avoid problems in eventual automatic or semi-automatic label dispensing
- Heat, used for ink drying, may have a negative effect on conversion or dispensing and should be avoided; if necessary a temperature level of 50°C should not be exceeded
- Printing can be done on all applicable label printing technologies
- To avoid adhesive bleed, label roll should not be wound tight, nor be exposed to elevated temperatures during storage

Basis Weight

81 g/m²

Thickness

64 µm

Print Technology

Conventional Press



VI

Test

Print Performance

Printability



Stiffness



Print Definition



Conformability



Print Durability



OBA

Tensile Strength



Wet Opacity



Water Resistance

-

Dry Opacity



MC90 OPQ FSC

A white wood-free super calandered paper with semi gloss appearance, specially treated in black on the reverse side to give opacity

Applications

Correction labelling, size changes, relabelling obsolete pre-printed packaging

Features

- FSC Certified
- Designed for use as an opaque coverall material, traditionally used for re-labelling or amending existing labels or packaging

Printing & Converting

- Can be used on all conventional label presses, UV Flexo, UV offset, Letterpress and Digital

Basis Weight

100 g/m²

Thickness

85 µm

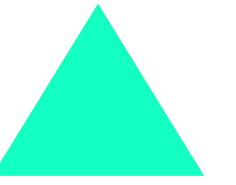

Print Technology

Conventional Press



VI

Test

Print Performance

Printability



Stiffness



Print Definition



Conformability



Print Durability



OBA



Tensile Strength



Wet Opacity



Water Resistance



Dry Opacity



Primax[®] Plus

A white, satin finished, machine direction oriented, corona-treated polyolefin film

Applications

Cosmetics, toiletries, detergents, home and personal care, semi-squeeze applications, tube labelling

Features

- Due to its flexibility, the product is especially suitable for semi-squeezable bottles and other semi-flexible containers
- Can also be used for tube labelling
- The clear, white finished film blends well into matte plastic containers, and can be over-varnished to obtain a high gloss
- The film has a machine direction orientation (MDO) which offers exceptional dimensional stability and allows cross directional conformability

Printing & Converting

- The corona treated film utilizes a print receptive “skin” for additional ink adhesion security
- Printable using all the usual printing techniques including UV letterpress, UV silkscreen, water based, UV flexo and hot foil blocking
- In-line corona treatment is recommended
- Press stability is high, minimizing wastage of material and press time
- Can be used for applications requiring printability via thermal transfer with suitable ribbons
- Material has excellent register properties especially when a high number of different colours are used

Basis Weight
75 g/m²

Thickness
76 µm

Print Technology

Conventional Press
✓

VI
Test

Print Performance

Printability
●●●●●

Stiffness
●●●●○

Print Definition
●●●●●

Conformability
●●●●○

Print Durability
●●●●●

OBA
–

Primax[®] I

A white, satin finished, machine direction oriented, corona-treated polyolefin film

Applications

Cosmetics, toiletries, detergents, home and personal care, semi-squeeze applications, chemical and industrial applications

Features

- A very high caliper and robust film, allowing reliable dispensing of large labels and complex label shapes
- Due to its flexibility, the product is suitable for semi-squeezable bottles and other semi-flexible containers
- The white, matte finished film blends well into matte plastic containers
- Can be over-varnished to obtain a high gloss finish
- The film has a machine direction orientation (MDO) which offers exceptional dimensional stability and allows cross directional conformability

Printing & Converting

- The engineered print skin can be printed by conventional printing techniques including flexo, screen, offset, letterpress, silkscreen, gravure, and hot or cold foiling processes
- UV, water-based and solvent-based inks can be used
- On-press corona treatment is recommended for optimum ink adhesion
- The face material is suitable for Thermal Transfer printing Exact inks, foils and ribbons should be specified by your ink/foil/ribbon supplier
- The material has excellent register properties especially when a high number of different colours are used
- In circumstances where high scuff resistance is required, overvarnish of the printed labels is advised

Basis Weight
101 g/m²

Thickness
88 µm

Print Technology

Conventional Press
✓

VI
Test

Print Performance

Printability
●●●●●

Stiffness
●●●●●

Print Definition
●●●●●

Conformability
●●●●●

Print Durability
●●●●●

OBA
–

GCX White

A white, flexible polyolefin film

Applications

Cosmetics, toiletries, detergents, home and personal care, semi-squeeze applications

Features

- The film has a machine direction orientation (MDO) which offers exceptional dimensional stability and allows cross directional conformability
- Suitable for applications requiring high quality graphics, together with consistent functional performance during automatic application and in end use
- Applications requiring high quality graphics together with consistent functional performance during automatic application and in end use
- Specially engineered films combine good MD rigidity and dispensability with high CD squeezability
- Suitable for use on semi-squeezable containers where continued flexing during end use is expected e.g. shampoo bottles
- A good alternative in applications where PVC is no longer accepted (recyclable

with Polyolefin & PET containers)

- Retains dyne level for longer periods due to print skin

Printing & Converting

- Global Co-Ex™ is extruded with a print-receptive skin. In-line corona treatment is required for good ink anchorage over a wide range of processes: rotary UV screen, UV letterpress, UV flexo, water flexo, and solvent gravure
- Over-varnish is required for high clarity and ultimate durability
- In-house testing is always recommended prior to final ink or hot/cold foil stamp selection
- Shows excellent register stability on press
- Higher temperature resistance compared to PE
- Caution should be exercised when printing UV screen inks and UV cured varnishes over the label's die cut edge
- Can be die cut and stripped at high speeds on standard web-fed presses using typical film tooling; excellent dispensability can be expected

Basis Weight

64 g/m²

Thickness

63 μm

Print Technology

Conventional Press



VI

Test

Print Performance

Printability



Stiffness



Print Definition



Conformability



Print Durability



OBA

–

GCX Clear

A clear, flexible polyolefin film

Applications

Cosmetics, toiletries, detergents, home and personal care, semi-squeeze applications

Features

- The film has a machine direction orientation (MDO) which offers exceptional dimensional stability and allows cross directional conformability
- Suitable for applications requiring high quality graphics, together with consistent functional performance during automatic application and in end use
- Specially engineered films combine good MD rigidity and dispensability with high CD squeezability
- Suitable for use on semi-squeezable containers where continued flexing during end use is expected e.g. shampoo bottles
- A good alternative in applications where PVC is no longer accepted (recyclable with Polyolefin & PET containers)
- Retains dyne level for longer periods due to print skin

Printing & Converting

- Global Co-Ex™ is extruded with a print-receptive skin. In-line corona treatment is required for good ink anchorage over a wide range of processes: rotary UV screen, UV letterpress, UV flexo, water flexo, and solvent gravure
- Over-varnish is required for high clarity and ultimate durability
- In-house testing is always recommended prior to final ink or hot/cold foil stamp selection
- Shows excellent register stability on press
- Higher temperature resistance compared to PE
- Caution should be exercised when printing UV screen inks and UV cured varnishes over the label's die cut edge
- Can be die cut and stripped at high speeds on standard web-fed presses using typical film tooling; excellent dispensability can be expected

Basis Weight

61 g/m²

Thickness

63 μm

Print Technology

Conventional Press



VI

Test

Print Performance

Printability



Stiffness



Print Definition



Conformability



Print Durability



OBA

–

Polyexact White

A white cast, top-coated co-extruded polyethelene film

Basis Weight
82 g/m²

Thickness
82 μm

Applications

Cosmetics, toiletries, detergents, home and personal care, high squeeze applications, tube labelling

Features

- Perfect for applications requiring high quality graphics
- Flexible nature is suitable for use on high squeeze containers where continued flexing during end use is expected e.g. squeezable tubes
- A good alternative in applications where PVC is no longer accepted (recyclable with Polyolefin & PET containers)
- Cast PE construction exhibits exceptional press stability

Printing & Converting

- Modified acrylic based topcoating can be printed by conventional printing techniques including flexo, screen, offset, letterpress, silkscreen, gravure, and hot or cold foiling processes
- UV and solvent-based inks can be used
- Topcoat is designed for optimal ink adhesion
- On-press corona treatment is not advised
- Face material is suitable for Thermal Transfer printing
- Exact inks, foils and ribbons should be specified by your ink/foil/ribbon supplier
- Material has excellent register properties especially when a high number of different colours are used

Print Technology

Conventional Press
✓

VI
Test

Print Performance

Printability
●●●●●

Stiffness
●●○○○

Print Definition
●●●●●

Conformability
●●●●●

Print Durability
●●●●●

OBA
-

Polyexact Clear

A clear gloss, top-coated co-extruded polyethylene film

Basis Weight
78 g/m²

Thickness
83 µm

Applications

Cosmetics, toiletries, detergents, home and personal care, high squeeze applications, tube labelling

Features

- Perfect for applications requiring high quality graphics
- Flexible nature is suitable for use on high squeeze containers where continued flexing during end use is expected e.g. squeezable tubes
- A good alternative in applications where PVC is no longer accepted (recyclable with Polyolefin & PET containers)
- Cast PE construction exhibits exceptional press stability

Printing & Converting

- Modified acrylic based topcoating can be printed by conventional printing techniques including flexo, screen, offset, letterpress, silkscreen, gravure, and hot or cold foiling processes
- UV and solvent-based inks can be used
- The topcoat is designed for optimal ink adhesion
- On-press corona treatment is not advised
- Face material is suitable for Thermal Transfer printing
- Exact inks, foils and ribbons should be specified by your ink/foil/ribbon supplier
- Material has excellent register properties especially when using a wide variety of different colours

Print Technology

Conventional Press
✓

VI Test

Print Performance

Printability
●●●●●

Stiffness
●●○○○

Print Definition
●●●●●

Conformability
●●●●●

Print Durability
●●●●●

OBA
—

Flex+ White NTC

A corona-treated, flexible, co-extruded white polyolefin film.

Basis Weight
50 g/m²

Thickness
55 µm

Applications

Cosmetics, toiletries, detergents, home and personal care, high squeeze applications, tube labelling

Features

- Designed for the prime label market, specifically the cosmetics, home and personal care segments, where clarity, conformability and adhesion to HDPE and PET containers are required.
- Recommended for those markets that require the recycling of polyolefin containers.
- Designed for the “No-Label” look decoration.

Printing & Converting

- Flex+ is extruded with a print-receptive skin. In-line corona treatment is required for good ink anchorage over a wide range of processes: rotary UV screen, UV letterpress, UV flexo, water flexo, and solvent gravure. Caution should be exercised when printing UV screen inks and UV cured varnishes over the label’s die cut edge. In-house testing is always recommended prior to final ink selection. Use of static elimination equipment is highly recommended. Flex+ shows excellent register stability on press. It has a higher temperature resistance compared to PE. Sharp dies especially for flat-bed die are important to ensure smooth conversion. For optimal dispensing a relatively high tension on the backing paper and a sharp applicator beak are recommended.

Print Technology

Conventional Press
✓

VI
Test

Print Performance

Printability
●●●○○

Stiffness
●●○○○

Print Definition
●●●○○

Conformability
●●●●○

Print Durability
●●●○○

OBA
—

Flex+ Clear NTC

A corona-treated, flexible, co-extruded clear polyolefin film.

Basis Weight
50 g/m²

Thickness
55 µm

Applications

Cosmetics, toiletries, detergents, home and personal care, high squeeze applications, tube labelling

Features

- Designed for the prime label market, specifically the cosmetics, home and personal care segments, where clarity, conformability and adhesion to HDPE and PET containers are required.
- Recommended for those markets that require the recycling of polyolefin containers.

Printing & Converting

- Flex+ is extruded with a print-receptive skin. In-line corona treatment is required for good ink anchorage over a wide range of processes: rotary UV screen, UV letterpress, UV flexo, water flexo, and solvent gravure. Caution should be exercised when printing UV screen inks and UV cured varnishes over the label's die cut edge. In-house testing is always recommended prior to final ink selection. Use of static elimination equipment is highly recommended. Flex+ shows excellent register stability on press. It has a higher temperature resistance compared to PE. Sharp dies especially for flat-bed die are important to ensure smooth conversion. For optimal dispensing a relatively high tension on the backing paper and a sharp applicator beak are recommended.

Print Technology

Conventional Press
✓

VI
Test

Print Performance

Printability
●●●○○

Stiffness
●●○○○

Print Definition
●●●○○

Conformability
●●●●○

Print Durability
●●●○○

OBA
—

rPP TC WHITE

A bi-axially oriented, glossy white polypropylene film with a print-receptive top coating

Basis Weight
42 g/m²

Thickness
65 µm

Applications

Cosmetics, personal care, household chemicals, food, beverage, dairy, promotional applications

Features

- Recycled PP film contains 30% PIW making this a more sustainable label option helping brands achieve higher recycled content in packaging
- Widely adopted for dairy and juice applications
- Suitable for applications requiring durability and resistance to moisture and chemicals
- Ideal for situations where labelling is required to be identical to substrate on polypropylene containers
- Can be used in environmentally sensitive markets requiring recycling of polyolefin packs

Printing & Converting

- Excellent printability and low incidence of gels & fish-eyes
- Printable using all conventional label printing technologies, including foil stamping
- Suitable for conventional die-cutting processes, contact your die consultant for details
- Suitable for conventional inks and varnishes, consult your ink specialist for details
- Corona treatment is not required
- Overlamination is typically not required but may be recommended for ultimate scuff resistance and high speed dispensing

Print Technology

Conventional Press
✓

VI
Test

Print Performance

Printability
●●●●●

Stiffness
●●●●○

Print Definition
●●●●●

Conformability
●●○○○

Print Durability
●●●●○

OBA
-

PP60 White NTC

A corona treated, gloss white bi-axially oriented, polypropylene film

Basis Weight
39 g/m²

Thickness
56 µm

Applications

Cosmetics, personal care, household chemicals, food, beverage, dairy, promotional applications

Features

- Widely adopted for dairy and juice applications
- Suitable for applications requiring moderate durability and resistance to moisture and chemicals
- Ideal for situations where labelling is required to be identical to substrate on polypropylene containers
- Can be used in environmentally sensitive markets requiring recycling of polyolefin packs
- Overlaminating film helps improve scuff resistance

Printing & Converting

- Printable using all conventional label printing technologies, conventional die-cutting processes and conventional inks and varnishes
- Cavitated films can sometimes exhibit poor scuff resistance in wet conditions, consult your ink specialist for details
- Relevant tests should be conducted on cold foil printing to determine its suitability
- Excessive press label rewind tension may cause labels to slip/misalign, or adhesive to bleed
- Anti-static devices are strongly recommended when converting film products and all dies should be proofed to the construction
- Corona treatment is recommended

Print Technology

Conventional Press
✓

VI
Test

Print Performance

Printability
●●●●○

Stiffness
●●●○●

Print Definition
●●●●○

Conformability
●●○●●

Print Durability
●●●○●

OBA
—

Opalux 80 NTC

A high caliper, gloss white cavitated bi-axially oriented, polypropylene film

Applications

Cosmetics, personal care, household chemicals, food, beverage, dairy, promotional applications

Features

- Higher caliper film offers excellent dispensing
- Widely adopted for dairy and juice applications
- Suitable for applications requiring moderate durability and resistance to moisture and chemicals
- Ideal for situations where labelling is required to be identical to substrate on polypropylene containers
- Can be used in environmentally sensitive markets requiring recycling of polyolefin packs

Printing & Converting

- Printable using all conventional label printing technologies, including foil stamping
- Suitable for conventional die-cutting processes, contact your die consultant for details
- Suitable for conventional inks and varnishes, consult your ink specialist for details
- Over-laminating is recommended for ultimate scuff resistance and high speed dispensing
- Corona treatment is recommended

Basis Weight
55 g/m²

Thickness
75 µm

Print Technology

Conventional Press
✓

VI
Test

Print Performance

Printability
●●●●○

Stiffness
●●●●○

Print Definition
●●●●○

Conformability
●○○○○

Print Durability
●●●○○

OBA
—

Pearlux 80 NTC

A gloss white pearlised cavitated bi-axially oriented, polypropylene film

Applications

Cosmetics, personal care, household chemicals, food, beverage, dairy, promotional applications

Features

- Higher caliper film offers excellent dispensing
- Widely adopted for dairy and juice applications
- Suitable for applications requiring moderate durability and resistance to moisture and chemicals
- Ideal for situations where labelling is required to be identical to substrate on polypropylene containers
- Can be used in environmentally sensitive markets requiring recycling of polyolefin packs

Printing & Converting

- Printable using all conventional label printing technologies, including foil stamping
- Suitable for conventional die-cutting processes, contact your die consultant for details
- Suitable for conventional inks and varnishes, consult your ink specialist for details
- Over-laminating is recommended for ultimate scuff resistance and high speed dispensing
- Corona treatment is recommended

Basis Weight
55 g/m²

Thickness
75 µm

Print Technology

Conventional Press
✓

VI
Test

Print Performance

Printability
●●●●○

Stiffness
●●●●○

Print Definition
●●●●○

Conformability
●○○○○

Print Durability
●●●○○

OBA
—

PP60 Top Pearlized White

A bi-axially oriented, glossy, pearlized white polypropylene film with a print-receptive top coating.

Applications

Beverage, food, HPC applications on PET bottles and containers

Features

- Applications are predominantly in market segments where rigid containers are used.
- Suitable for labelling of quality products such as cosmetics, toiletries, luxury articles, promotional labelling, automotive lubricants and household chemicals where durability and resistance to moisture or chemicals are required.
- The “pearlized white” appearance of the facestock gives a unique and premium look offering excellent shelf appeal.
- Ideal for applications requiring ‘substrate identical labelling’ on polypropylene containers and in environmentally sensitive markets requiring recycling of ‘polyolefin’ packs.
- Due to fairly rigid nature of polypropylene, care should be taken with the use on ‘nonuniform’ surfaces or where a high level of squeezability is desired.

Printing & Converting

- The topcoating allows printing by the conventional printing technologies including letterpress, flexo, gravure, screen printing, giving good results with solvent, UV curing and water based inks. The facestock can also be printed with thermal transfer when matched with the correct ribbon. In case solvent screen inks are used, please consult your ink manufacture. Material shows excellent register stability on press and excellent flat bed conversion while rotary and magnetic dies need additional care. Square corners should be avoided.

Basis Weight
45 g/m²

Thickness
60 µm

Print Technology

Conventional Press ✓	VI –
--------------------------------	----------------

Print Performance

Printability
●●●●●

Stiffness
●●●●○

Print Definition
●●●●●

Conformability
●●●●○

Print Durability
●●●●●

OBA
–

PP40 TC Clear

A light weight biaxially oriented, gloss clear polypropylene film with a print receptive top coating

Basis Weight
37 g/m²

Thickness
40 μm

Applications

Cosmetics, personal care, household chemicals, food, beer, wine, beverage, dairy, promotional applications

Features

- Thin construction allows more labels per roll, leading to less wastage and reducing freight & packaging costs
- Predominately used in clear label applications for beer and beverages
- Suitable for applications requiring high-quality graphics with consistent functional performance during automatic application and in end use
- Ideal for use on high-speed application lines (such as beer labeling) when combined with a suitable adhesive and PET liner
- For use where very high levels of clarity are required to achieve a “no label look”

Printing & Converting

- Printable using all conventional label printing technologies
- Corona treatment effectiveness reduces over time and can be affected by abrasion/ damage caused by web friction
- To ensure optimum wettability and ink bond, additional in-line corona treatment is required
- An over-laminate is recommended for print protection
- Excellent register stability on press and flat bed conversion - additional care required with rotary and magnetic dies

Print Technology

Conventional Press ✓	VI -
--------------------------------	----------------

Print Performance

Printability
●●●●●

Stiffness
●●○○○

Print Definition
●●●●●

Conformability
●●●○○

Print Durability
●●●●○

OBA
-

PP50 TC Clear

A bi-axially oriented, gloss clear polypropylene film with a print-receptive top coating

Applications

Cosmetics, personal care, household chemicals, food, beer, wine, beverage, dairy, promotional applications

Features

- Predominately used in clear label applications for beer and beverages
- Suitable for applications requiring high-quality graphics with consistent functional performance during automatic application and in end use
- Ideal for use on high-speed application lines (such as beer labeling) when combined with a suitable adhesive and PET liner
- For use where very high levels of clarity are required to achieve a “no label look”

Printing & Converting

- Printable using all conventional label printing technologies, including foil stamping
- Corona treatment effectiveness reduces over time and can be affected by abrasion/ damage caused by web friction
- To ensure optimum wettability and ink bond, additional in-line corona treatment is required
- An over-laminate is recommended for print protection
- Excellent register stability on press and flat bed conversion - additional care required with rotary and magnetic dies

Basis Weight
47 g/m²

Thickness
50 μm

Print Technology

Conventional Press ✓	VI -
--------------------------------	----------------

Print Performance

Printability
●●●●●

Stiffness
●●●●○

Print Definition
●●●●●

Conformability
●●○○○

Print Durability
●●●●○

OBA
-

PP OLF-20

A gloss clear BOPP overlaminating film

Applications

Printed surfaces

Features

- Overlaminating film to protect printed surfaces
- For use where clarity and protection is paramount

Printing & Converting

- Complex shaped labels and square corners may limit conversion speed

Basis Weight

18 g/m²

Thickness

20 μm

Print Technology

Conventional Press



VI



Print Performance

Printability



Stiffness



Print Definition



Conformability



Print Durability



OBA



PVC White

A white, monomerically plasticised PVC film

Basis Weight
112 g/m²

Thickness
84 µm

Applications

Industrial and chemical applications

Features

- Suitable for indoor and outdoor use requiring good durability and weatherability

Printing & Converting

- Corona treated face material can be printed by conventional printing techniques including flexo, screen, offset, letterpress, silkscreen, gravure, and hot or cold foiling processes
- UV, water-based and solvent based inks can be used
- On-press corona treatment is recommended for optimum ink adhesion
- Use of a primer in the printing process is strongly recommended
- Face material is suitable for Thermal Transfer printing
- Exact inks, foils and ribbons should be specified by your ink/foil/ribbon supplier

Print Technology

Conventional Press
✓

VI
Test

Print Performance

Printability
●●●●○

Stiffness
●●●●○

Print Definition
●●●●○

Conformability
●●●●○

Print Durability
●●●●○

OBA
–

PP50 TC Silver

A glossy, metalised BOPP film with a print receptive top coating

Basis Weight
46 g/m²

Thickness
50 µm

Applications

Cosmetics, personal care, food, beer, wine, beverage, dairy, promotional & luxury articles

Features

- Premium silver gloss film for a 'mirror effect'
- Ideal for situations requiring a luxury metallic look
- Due to the fairly rigid nature of the film, care should be taken with use on non-uniform surfaces and where a very high level of squeezability is desired

Printing & Converting

- Printable using all conventional label printing technologies
- Suitable for conventional die-cutting processes and conventional inks and varnishes, consult your ink specialist for details
- Over-laminating film helps improve scuff resistance

Print Technology

Conventional Press
✓

VI Test

Print Performance

Printability
●●●●○

Stiffness
●●○○○

Print Definition
●●●●○

Conformability
●●●○○

Print Durability
●●●●○

OBA
-

PP80 White Dig TC

HP Indigo, high caliper, printable top-coated biaxially oriented, white polypropylene film

Basis Weight
62 g/m²

Thickness
80 µm

Applications

Cosmetics, personal care, household chemicals, food, beverage, dairy, promotional applications

Features

- Suitable for use with HP Indigo presses
- Applications are predominantly in areas requiring high quality graphics together with consistent functional performance during automatic application and in end use

Printing & Converting

- Facestock is treated with indigo printable topcoat suitable for indigo printing
- Can be die-cut and stripped at high speeds on standard web-fed presses with either flatbed or rotary dies
- For best performance it is recommended to have dies tooled specifically for this construction
- Offers excellent dispensing characteristics

Print Technology

Conventional Press
Digital

VI
Test

Print Performance

Printability
●●●●●

Stiffness
●●●●●

Print Definition
●●●●●

Conformability
●○○○○

Print Durability
●●●●●

OBA
—

Zig Zag FSC

A high white, uncoated, matte wood-free paper

Applications

Ideally suited for the manufacture of continuous form labels for applications such as dispatch, stock control and instructional labels

Features

- FSC Certified
- Zig Zag is a general purpose dot matrix printable facestock
- Ideally suited for the manufacture of continuous form labels for applications such as dispatch, stock control and instructional labels

Printing & Converting

- Facestock is suitable for single and/or multicolour line or process by printing flexo, offset and letterpress
- The product is designed to be converted and dispensed at high speed by all conventional roll conversion technologies

Basis Weight

68 g/m²

Thickness

66 µm

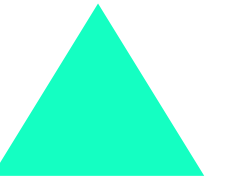

Print Technology

Conventional Press



VI



Print Performance

Printability



Stiffness



Print Definition



Conformability



Print Durability



OBA

Tensile Strength



Wet Opacity

Water Resistance

Dry Opacity

Direct Thermal 200HD FSC

A white, back coated wood-free paper with a barrier-coated, thermosensitive layer

Applications

Retail, deli, wet meat-packing, cryovac food, freeze-thaw (meat and fish), cheese, industrial barcoding and tracking

Features

- FSC certified
- Suitable for barcode labeling where excellent resistance to moisture, oils and fats is required in the retail and industrial sectors (e.g. pre-packed food, meat & fish, laboratory items and pharmaceutical vials)

Note: This product is not recommended for applications where labels are exposed to direct sunlight or temperatures above 50°C

Printing & Converting

- Can be used on all conventional label printing technologies
- UV Flexo and Letterpress are recommended
- Suitable for conventional die-cutting processes and conventional inks and varnishes, consult specialists for details
- Thermal coating may exhibit poor scuff resistance in wet environments
- Inks containing alcohol or volatile organic solvents may cause discolouration of the thermosensitive coating

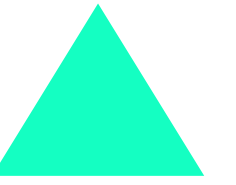

Basis Weight
78 g/m²

Thickness
81 µm

Print Technology

Conventional Press
✓

VI
✓

Print Performance

Printability
●●●●●

Stiffness
●●●●○

Print Definition
●●●●●

Conformability
●●○○○

Print Durability
●●●●○

OBA
✓

Tensile Strength
●●●●●

Wet Opacity
●●●●●

Water Resistance
●●●●●

Dry Opacity
●●●●●

DT150RL FSC

An FSC certified, white wood-free paper with a barrier-coated thermo-sensitive layer

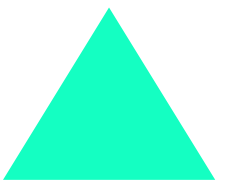

Basis Weight
73 g/m²

Thickness
74 µm

Applications

Suitable for general purpose barcode labelling for retail and industrial items e.g. pre-packed food in dry environments, meat and fish, grocery weigh scale, industrial tracking and warehousing applications

Features

- FSC certified
- Suitable for general purpose barcode labeling for retail and industrial items (e.g. pre-packed food in dry environments, meat & fish, grocery weigh scale, industrial tracking and warehousing applications)
- For extremely demanding applications where the labels are in direct contact with fats and oil for extended periods of time (i.e. a couple of hours), Avery Dennison recommends DT200HD

Note: This product is not recommended for applications where labels are exposed to direct sunlight or temperatures above 50°C

Printing & Converting

- Can be used on all conventional label printing technologies. UV Flexo and Letterpress are recommended
- Suitable for conventional die-cutting processes and conventional inks and varnishes. Consult specialists for details
- Thermal coating may exhibit poor scuff resistance in wet environments
- Inks containing alcohol or volatile organic solvents may cause discolouration of the thermo-sensitive coating

Print Technology

Conventional Press
✓

VI
✓

Print Performance

Printability
●●●●●

Stiffness
●●●●○

Print Definition
●●●●●

Conformability
●●○○○

Print Durability
●●●○

OBA
✓

Tensile Strength
●●●●○

Wet Opacity
●●●●●

Water Resistance
●●●●○

Dry Opacity
●●●●●

rDT300LD BPAF FSC

A white, wood-free paper with a thermo-sensitive layer, consists of 15% recycled content. The facestock is made from FSC certified paper

Applications

Warehouse logistics and address labelling, barcode labels printed on in store price weight equipment and non-food items in retail stores (e.g. Magazines)

Features

- FSC certified
- Suitable for applications where the environment is dry and the label life cycle is short. i.e. warehouse logistics and address labelling, barcode labels printed on instore price weight equipment and non-food items in retail stores (e.g. magazines)
- For applications where the labels are exposed to moisture, oil, grease and plasticisers, Avery Dennison recommends DT200HD or DT200GPN.

Note: This product is not recommended for applications where labels are exposed to direct sunlight or temperatures above 50°C

Printing & Converting

- Can be used on all conventional label printing technologies
- UV Flexo and Letterpress are recommended
- Suitable for conventional die-cutting processes and conventional inks and varnishes
- Consult specialists for details
- Thermal coating may exhibit poor scuff resistance in wet environments
- Inks containing alcohol or volatile organic solvents may cause discolouration of the thermo-sensitive coating

Basis Weight
70 g/m²

Thickness
75 µm

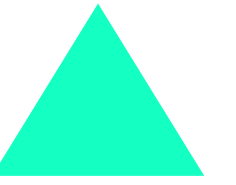

Print Technology

Conventional Press
✓

VI
✓

Print Performance

Printability
●●●●○

Stiffness
●●●●○

Print Definition
●●●●○

Conformability
●●○○○

Print Durability
●●●○○

OBA

Tensile Strength
●●●●●

Wet Opacity
●●○○○

Water Resistance
●●○○○

Dry Opacity
●●●●●

DT60 TC

A white, wood-free paper with a barrier-coated thermo-sensitive layer. The facestock is made from FSC certified paper

Applications

Application areas include warehouse logistics, shipping & tracking label, retail items in dry environment (e.g. nuts, magazines, etc). Not recommended on the PVC substrate

Features

- Designed for use in thermal printing that demands good printability
- Suitable for barcode labelling in dry environments

Printing & Converting

- Can be used on conventional label printing technologies
- Thermal coating may exhibit poor scuff resistance in wet environments
- Inks containing alcohol or volatile organic solvents may cause discolouration of the thermo-sensitive coating

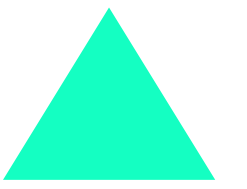

Basis Weight
60 g/m²

Thickness
60 µm

Print Technology

Conventional Press
✓

VI
✓

Print Performance

Printability
●●●●●

Stiffness
●●●●○

Print Definition
●●●●●

Conformability
●●○○○

Print Durability
●●●●○

OBA
✓

Tensile Strength
●●●●○

Wet Opacity
●●●●●

Water Resistance
●●●●○

Dry Opacity
●●●●●

Premium Therm TC25 Linerless

A smooth white matte paper coated with a black imaging thermo sensitive coating & protective top coating. It has excellent resistance to water, oil, and moisture.

Basis Weight
78 g/m²

Thickness
81 µm

Applications

Suitable for general purpose barcode labelling for retail and logistics applications

Features

- This product is designed for use in linerless weight scale & barcode printers. Suitable for general purpose barcode labeling for retail and industrial items (e.g. pre-packed food in dry environments, meat & fish, grocery weigh scale, industrial tracking and warehousing applications)
- For extremely demanding applications where the labels are in direct contact with fats and oil for extended periods of time (i.e. a couple of hours), Avery Dennison recommends DT200HD

Note: This product is not recommended for applications where labels are exposed to direct sunlight or temperatures above 50°C

Printing & Converting

- This product needs special converting equipment to convert. Due to the thermal sensibility, exposure to sunshine or above 50°C should be avoided. Solvent may cause damage to surface coating; care should be taken when using solvent based inks.

Print Technology

Conventional Press	VI
–	✓

Print Performance

Printability
●●●●●

Stiffness
●●●●●

Print Definition
●●●●●

Conformability
●●●●●

Print Durability
●●●●●

OBA
–

Tensile Strength
●●●●●

Wet Opacity
●●●●●

Water Resistance
●●●●●

Dry Opacity
●●●●●

TT Elite FSC

A matte-coated paper designed for high quality thermal transfer applications

Applications

Applications include logistics, identification and tracking labels in offices hospitals, libraries and retail environments

Features

- FSC Certified
- TT Elite is designed for use in the highest quality thermal transfer applications
- TT Elite offers superior environmental resistance and image durability compared to Avery Dennison's Direct Thermal papers

Printing & Converting

- Printable using all conventional label printing technologies, including foil stamping
- Suitable for conventional die-cutting processes, consult your die-consultant for details
- Suitable for conventional inks and varnishes for thermal transfer processes, consult your ink specialist for details

Note: *Not recommended for moist applications*

Basis Weight
75 g/m²

Thickness
74 μm

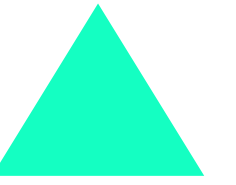

Print Technology

Conventional Press
✓

VI
✓

Print Performance

Printability
●●●●●

Stiffness
●●●○

Print Definition
●●●●●

Conformability
●○○○○

Print Durability
●●●●●

OBA
✓

Tensile Strength
●●●●●

Wet Opacity
●●●●●

Water Resistance
●●●●●

Dry Opacity
●●●●●

LCJ Premium

A matte white wood-free machine paper with excellent print absorption and toner bonding characteristics

Applications

Applications include office, instruction, inventory and address labels

Features

- FSC Certified
- Suitable for use in photocopiers, laser and inkjet printers for domestic and commercial applications
- LaserCopyJet features excellent toner bonding with laser printers and very good smudge resistance with inkjet printers

Printing & Converting

- This product suit for all the usual printing technologies
- Suit to medium pre printing quality requirement
- Excellent conversion characteristics in rotary and flat-bed

Basis Weight

64 g/m²

Thickness

72 μm

Print Technology

Conventional Press



VI



Print Performance

Printability



Stiffness



Print Definition



Conformability



Print Durability



OBA

Tensile Strength



Wet Opacity

Water Resistance

Dry Opacity

LCJ Premium FSC

A matte white wood-free machine paper with good print absorption and toner bonding characteristics

Applications

A4 sheets for home office, office, instruction, inventory and address labels

Features

- Suitable for use in photocopiers, laser and inkjet printers for domestic and commercial applications
- Applications include office, instruction, inventory and address labels
- LaserCopyJet features excellent toner bonding with laser printers and very good smudge resistance with inkjet printers

Printing & Converting

- Facestock is suitable for simple line or process printing by flexo and offset
- The material can be converted by the conventional roll-to-sheet conversion technologies

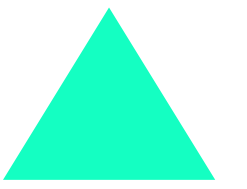

Basis Weight
64 g/m²

Thickness
75 µm

Print Technology

Conventional Press
✓

VI
✓

Print Performance

Printability
●●●●●

Stiffness
●●●○○

Print Definition
●●●●●

Conformability
●○○○○

Print Durability
●●●○○

OBA

Tensile Strength
●●○○○

Wet Opacity

Water Resistance

Dry Opacity

Laserpro FSC

A matte white wood-free machine paper with good print absorption and toner bonding characteristics

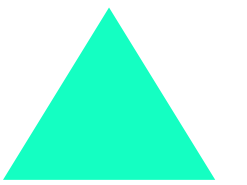

Basis Weight
70 g/m²

Thickness
80 μm

Applications

A4 sheets for home office, office, instruction, inventory and address labels

Features

- FSC Certified
- Suitable for use in photocopiers, laser and inkjet printers for domestic and commercial applications
- Applications include office, instruction, inventory and address labels

Printing & Converting

- The product has tightly defined release characteristics to avoid pre-dispensing during the printing or copying process
- The well balanced laminate construction ensures optimum lay flatness during conversion and end-use under a relatively wide range of conditions
- This material can be converted by the conventional roll-to-sheet conversion technologies
- The facestock's surface structure provides excellent toner bonding and print

Print Technology

Conventional Press
✓

VI
✓

Print Performance

Printability
●●●●○

Stiffness
●●●○○

Print Definition
●●●○○

Conformability
●○○○○

Print Durability
●●●○○

OBA

Tensile Strength
●●○○○

Wet Opacity

Water Resistance

Dry Opacity

Gloss IJ Paper FSC

A white, high gloss printing paper with a specific topcoating for excellent transfer and anchorage using the Inkjet process

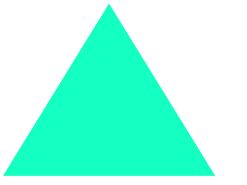

Basis Weight
88 g/m²

Thickness
106 µm

Applications

Primary and secondary packaging labels in retail, manufacturing, healthcare, and logistics

Printing & Converting

- The product is designed to be converted and by all conventional converting technologies

Features

- Specially engineered for use in on-demand ink jet printers
- The high ink holdout and quick drying provide for excellent clarity and density of printed graphics, making it the perfect choice for primary and secondary packaging labels in retail, manufacturing, health care and logistics etc.
- Ideal for printing labels in on-demand colour inkjet printers, where full process colour is used to add impact and/or functionality to the label

Print Technology

Conventional Press
✓

VI
✓

Print Performance

Printability
●●●●●

Stiffness
●●●●●

Print Definition
●●●●●

Conformability
●○○○○

Print Durability
●●●●●

OBA

Tensile Strength
●●●○○

Wet Opacity

Water Resistance

Dry Opacity

DT300N

A white BOPP film coated with a thermosensitive layer

Basis Weight
70 g/m²

Thickness
85 µm

Applications

Pre-packed food (e.g meat, fish, poultry, and fish) and industrial barcoding (e.g laboratories, hospitals, and pharmaceutical applications)

Features

- Designed for use in thermal printing at print speed up to 300mm/s and where image resistance is required (Based on printer's set-up)
- Suitable for barcode labelling where labels come into contact with moisture, fats and oils. i.e. Meat processing plants
- Features excellent environmental resistance and good label stiffness which assists in label and dispensing in print and apply applications
- Avoid prolonged temperature of 50°C or more for long periods
- Exposure to direct sunlight or strong fluorescent light may invalidate the image

Printing & Converting

- Printable using all conventional label printing technologies, UV Flexo and Letterpress are recommended
- Suitable for conventional die-cutting processes, consult your die-consultant for details
- Suitable for conventional inks and varnishes, consult your ink specialist for details

Print Technology

Conventional Press Test VI ✓

Print Performance

Printability **Stiffness**
●●●●● ○

Print Definition **Conformability**
●●●●● ●○○○○

Print Durability **OBA**
●●●●●

Polythermal Plus

A white BOPP film coated with a thermosensitive layer

Basis Weight

68 g/m²

Thickness

83 µm

Applications

Industrial, meat processing

Features

- Designed for use in thermal printing at print speed up to 300mm/s and where image resistance is required (Based on printer's set-up)
- Suitable for barcode labelling where labels come into contact with moisture, fats and oils. i.e. Meat processing plants
- Features excellent environmental resistance and good label stiffness which assists in label and dispensing in print and apply applications
- Avoid prolonged temperature of 50°C or more for long periods
- Exposure to direct sunlight or strong fluorescent light may invalidate the image.

Printing & Converting

- Printable using all conventional label printing technologies, UV Flexo and Letterpress are recommended
- Suitable for conventional die-cutting processes, consult your die-consultant for details
- Suitable for conventional inks and varnishes, consult your ink specialist for details

Print Technology

Conventional Press



VI



Print Performance

Printability



Stiffness

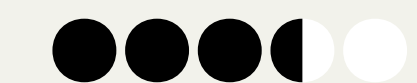

Print Definition



Conformability



Print Durability



OBA



Synthetic Paper

A matte white BOPP film with a smooth, absorbent, ink receptive topcoating

Applications

cosmetics, toiletries, luxury articles and promotional labeling as well as durable, outdoor, industrial applications, chemical drums labelling, automotive lubricants and household chemicals

Features

- High opacity polypropylene film which is suitable for flexographic, letterpress, screen & thermal transfer printing
- High strength and durability as well as good moisture and chemical resistance
- This product is suitable for use in a wide range of durable labelling applications whereby UL recognition is required. This product is UL recognized for indoor service

Printing & Converting

- The material can be converted and printed by all conventional printing technologies Litho-offset, flexographic, letterpress and screen
- In house testing is always recommended prior to final ink selection

Basis Weight

68 g/m²

Thickness

75 µm

Print Technology

Conventional Press



VI



Print Performance

Printability



Stiffness



Print Definition



Conformability



Print Durability



OBA



Data PE 80

A matte white, clay coated, cavitated, biaxially-oriented PE film with a smooth, absorbent, ink receptive topcoating

Applications

Durable, outdoor, industrial applications, chemical drums labelling

Features

- Ideally suited to thermal transfer applications where environmental resistance and moderate outdoor durability is required
- Good conformability
- Outdoor durability of up to 6 months can be expected in favourable conditions where the product is sheltered from rain, wind and direct sunlight

Printing & Converting

- Printable using all conventional label printing technologies, including foil stamping
- Suitable for conventional die-cutting processes, consult your die-consultant for detail
- Suitable for conventional inks and varnishes, consult your ink specialist for detail
- The clay coated surface allows for high print definition.
Note: Friction cleaning (Web wipers) can cause dust
- Films can sometimes exhibit poor scuff resistance in wet environments, consult your ink specialist for detail
- Excessive press label rewind tension may cause labels to slip/misalign, or adhesive to bleed
- When converting filmic products, anti-static devices are strongly recommended and all dies should be proofed to the construction

Basis Weight
75 g/m²

Thickness
95 µm

Print Technology

Conventional Press
✓

VI
✓

Print Performance

Printability
●●●●●

Stiffness
●●○○○

Print Definition
●●●●●

Conformability
●●●●○

Print Durability
●●●●●

OBA
-

2M PET Range

2 Mil print-treated polyester featuring excellent tear strength, heat resistance, dimensional stability, opacity and chemical resistance

Applications

Durable, outdoor, industrial applications, product identification labels, rating plates, work in progress (WIP) labels and asset tags

Features

- Print treatment is designed to enhance printability with a variety of printing processes
- UL recognised for indoor and outdoor applications

Printing & Converting

- The print treated surface is designed for printing by most solvent, UV cured, and water-based flexographic inks, UV cured letterpress, and rotary screen inks
- Specially formulated inks are normally not necessary, however, testing is recommended prior to final ink selection
- This product can be die cut and stripped at high speeds on most web-fed presses
- Sample labels in a variety of shapes have been successfully dispensed and applied with standard labeling systems

Basis Weight
75 g/m²

Thickness
50 µm

Print Technology

Conventional Press
✓

VI
✓

Print Performance

Printability
●●●●●

Stiffness
●●●●●

Print Definition
●●●●●

Conformability
●●○○○

Print Durability
●●●●○

OBA
-

Dataflex

A matte white synthetic film

Applications

Durable, outdoor, industrial applications, chemical drums labelling

Features

- Designed for use in applications using black and white (not colour) laser and thermal transfer printers
- Ideally suited to applications where environmental resistance and limited outdoor durability is required i.e. drum labelling
- Outdoor durability of up to 6 months can be expected in favourable conditions where the product is sheltered from rain, wind and direct sunlight

Note: Dataflex is not guaranteed through laser copiers / printers. High tempratures can cause jamming as the stock can get fused onto the drum/print head. Dataflex is NOT recommended for colour printers and should be trialled thoroughly before using for these applications

Printing & Converting

- Printable using all conventional label printing technologies, including foil stamping
- Suitable for conventional die-cutting processes, consult your die-consultant for details
- Suitable for conventional inks and varnishes, consult your ink specialist for details
- The clay coated surface allows for high print definition

Basis Weight

109 g/m²

Thickness

178 µm

Print Technology

Conventional Press



VI



Print Performance

Printability



Stiffness



Print Definition



Conformability



Print Durability



OBA



100um IJ SYN Paper

A matte white, synthetic paper with a specific topcoating for excellent transfer and anchorage using the Inkjet process

Basis Weight
69 g/m²

Thickness
100 µm

Applications

Primary and secondary packaging labels in retail, manufacturing, healthcare, and logistics

Printing & Converting

- The product is designed to be converted by all conventional converting technologies

Features

- Designed for use in on-demand colour inkjet printers, such as Epson TM-C 3520 and Memjet inkjet printing platforms, where full process colours used to add impact and/or functionality to the label
- The high ink holdout and quick drying provide for excellent clarity and density of printed graphics
- Ideal for primary and secondary packaging labels in retail, manufacturing, health care, and logistics etc.

Print Technology

Conventional Press
✓

VI
✓

Print Performance

Printability
●●●●●

Stiffness
●●●●○

Print Definition
●●●●○

Conformability
●●●●○

Print Durability
●●●●○

OBA

Cast Gloss Elite FSC

A white, one side cast coated, gloss finished, wood-free printing paper

Applications

Pharmaceutical, wine & spirits, high end food and beverage packaging

Features

- FSC Certified
- High gloss coating giving brilliant multicolour print quality and attractive gloss appearance
- Good resistance to edge wicking where some contact with water may occur
- Good scuff and environmental resistance when offered with a suitable varnish, but is not suitable for outdoor use
- High exposure to moisture may cause product to exhibit edge-wicking

Printing & Converting

- Printable using all conventional label printing technologies, including foil stamping
- Suitable for conventional die-cutting processes and conventional ink and varnishes
- Can be embossed and/or hot foil stamped
- Consult your ink specialist for details. Over-laminating film helps improve scuff and moisture resistance

Basis Weight
80 g/m²

Thickness
84 µm

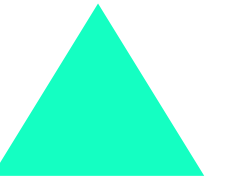

Print Technology

Conventional Press
✓

VI
Test

Print Performance

Printability
●●●●●

Stiffness
●●●●●

Print Definition
●●●●●

Conformability
●○○○○

Print Durability
●●●●●

OBA
✓

Tensile Strength
●●●●●

Wet Opacity
●●●●○

Water Resistance
●●●●●

Dry Opacity
●●●●●

Super White Opaque FSC

A bright white uncoated paper featuring a proprietary moisture resistant coating on both sides

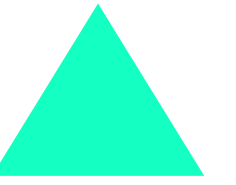

Basis Weight
110 g/m²

Thickness
130 µm

Applications

Wine & spirits, high end food and beverage packaging

Features

- FSC Certified
- Wet strength properties assist in retaining the strength of the paper fibres when exposed to moisture or wet environments
- Polymer coating on both sides provides superior moisture barrier properties and thereby improves ice-bucket performance by retaining opacity for longer periods
- Not recommended for neck labels or tight mandrel applications due to high stiffness
- Not available with removable or repositionable adhesives

Printing & Converting

- Printable using all conventional label printing technologies including foil stamping
- Due to the textured nature of the face material, flexography and offset printing will offer the best results
- Suitable for conventional die-cutting processes, contact your die-consultant for details
- Suitable for conventional inks and varnishes, contact your ink specialist for details
- Can be further embellished using foil stamping and embossing
- High levels of embossing could impair the moisture barrier and reduce adhesion / mandrel performance
- Labels must have a 3mm grain free zone measured from label edges
- The use of over-varnish is essential to enhance surface water repellance
- Refer to Wine Technical Brochure for more PS application considerations

Print Technology

Conventional Press
✓

VI
-

Print Performance

Printability
●●●●○

Stiffness
●●●●○

Print Definition
●●●●○

Conformability
●●○○○

Print Durability
●●●●○

OBA

Tensile Strength

Wet Opacity
●●●●●

Water Resistance

Dry Opacity
●●●●●

Estate #8 PE FSC

A creamy white vellum paper featuring wet strength properties and an extruded PE coated underlamine

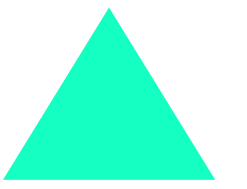

Basis Weight
114 g/m²

Thickness
140 µm

Applications

Wine & spirits, high end food and beverage packaging

Features

- FSC Certified
- Features wet strength properties which assist in retaining the strength of the paper fibres when exposed to moisture or wet environments
- Polymer underlamine improves moisture barrier properties and reduces the severity of paper fibre swelling induced “bubbling” on difficult substrates
- Not recommended for neck labels or tight mandrel applications due to high stiffness
- Not available with removable or repositionable adhesives

Printing & Converting

- Printable using all conventional label printing processes, however the textured nature of the facestock means that it is better suited to offset printing
- Can be further embellished using foil stamping and embossing
- High levels of embossing could impair the moisture barrier and reduce adhesion / mandrel performance
- Labels must have a 3mm grain free zone measured from label edges
- Suitable for conventional die-cutting processes, contact your die-consultant for details
- Suitable for conventional inks and varnishes, contact your ink specialist for details
- The use of over-varnish is essential to enhance surface water repellency
- Refer to Wine Technical Brochure for more PS application considerations

Print Technology

Conventional Press
✓

VI
-

Print Performance

Printability
●●●●○

Stiffness
●●●●○

Print Definition
●●●●○

Conformability
●●○○○

Print Durability
●●●●○

OBA
✓

Tensile Strength

Wet Opacity
●●●●○

Water Resistance

Dry Opacity
●●●●●

Estate #4 PE FSC

A white laid paper featuring wet strength properties and an extruded PE coated underlamine

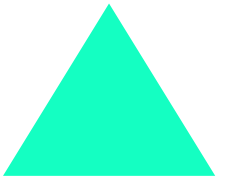

Basis Weight
109 g/m²

Thickness
139 µm

Applications

Wine & spirits, high end food and beverage packaging

Features

- FSC Certified
- Features wet strength properties which assist in retaining the strength of the paper fibres when exposed to moisture or wet environments
- Polymer underlamine improves moisture barrier properties and reduces the severity of paper fibre swelling induced “bubbling” on difficult substrates
- Not recommended for neck labels or tight mandrel applications due to high stiffness
- Not available with removable or repositionable adhesives

Printing & Converting

- Printable using all conventional label printing processes, however the textured nature of the facestock means that it is better suited to offset printing
- Can be further embellished using foil stamping and embossing
- High levels of embossing could impair the moisture barrier and reduce adhesion / mandrel performance
- Labels must have a 3mm grain free zone measured from label edges
- Suitable for conventional die-cutting processes, contact your die-consultant for details
- Suitable for conventional inks and varnishes, contact your ink specialist for details
- The use of over-varnish is essential to enhance surface water repellency
- Refer to Wine Technical Brochure for more PS application considerations

Print Technology

Conventional Press
✓

VI
-

Print Performance

Printability
●●●●○

Stiffness
●●●●○

Print Definition
●●●●○

Conformability
●●○○○

Print Durability
●●●●○

OBA

Tensile Strength

Wet Opacity
●●●●○

Water Resistance

Dry Opacity
●●●●●

Vintage FSC

A creamy white uncoated, textured paper featuring a proprietary moisture resistant coating on both sides

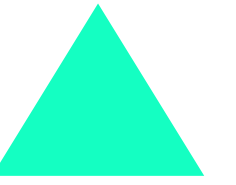

Basis Weight
110 g/m²

Thickness
130 µm

Applications

Wine & spirits, high end food and beverage packaging

Features

- FSC Certified
- Wet strength properties assist in retaining the strength of the paper fibres when exposed to moisture or wet environments
- Polymer coating on both sides provides superior moisture barrier properties and thereby improves ice-bucket performance by retaining opacity for longer periods
- Not recommended for neck labels or tight mandrel applications due to high stiffness
- Not available with removable or repositionable adhesives

Printing & Converting

- Printable using all conventional label printing technologies including foil stamping
- Due to the textured nature of the face material, flexography and offset printing will offer the best results
- Suitable for conventional die-cutting processes, contact your die-consultant for details
- Suitable for conventional inks and varnishes, contact your ink specialist for details
- Can be further embellished using foil stamping and embossing
- High levels of embossing could impair the moisture barrier and reduce adhesion / mandrel performance
- Labels must have a 3mm grain free zone measured from label edges
- The use of over-varnish is essential to enhance surface water repellance
- Refer to Wine Technical Brochure for more PS application considerations

Print Technology

Conventional Press
✓

VI
-

Print Performance

Printability
●●●●○

Stiffness
●●●●○

Print Definition
●●●●○

Conformability
●●○○○

Print Durability
●●●●○

OBA

Tensile Strength

Wet Opacity
●●●●●

Water Resistance

Dry Opacity
●●●●●

Maxflex Bright Silver FSC

A premium finish metallised paper with an acrylic topcoat

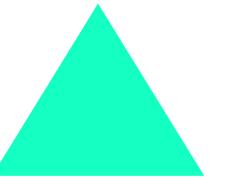

Basis Weight
83 g/m²

Thickness
66 µm

Applications

Wine & spirits, high end food and beverage packaging

Features

- FSC Certified
- Designed for decorative labelling of wine, spirits, beverage and premium food products
- Features a top-coating engineered to provide excellent printability
- High internal bond for scratch resistance performance
- High gloss and brightness to give excellent shelf appeal
- High levels of moisture exposure may exhibit edge wicking and label damage
- Prior testing before use in these environments is highly recommended

Printing & Converting

- Printable using all conventional label printing technologies, including foil stamping
- Suitable for conventional die-cutting processes, contact your die consultant for details
- Suitable for conventional inks and varnishes, consult your ink specialist for details
- Over-laminating film helps improve scuff resistance and moisture resistance
- Complex shaped labels and square corners may limit the conversion speed
- A suitable varnish will improve the durability of the label
- High levels of embossing will reduce mandrel and adhesion performance

Print Technology

Conventional Press
✓

VI
-

Print Performance

Printability
●●●●○

Stiffness
●●●○

Print Definition
●●●●○

Conformability
●●○○○

Print Durability
●●●●○

OBA

Frozen Orion Diamond V2 Plus FSC

A wood-free paper with a silver pearlescent textured look, with fungicidal treatments and a PET film underlamine

Applications

Wine & spirits, high end food and beverage packaging

Features

- Featuring a silky tactile feel making it ideal for luxury wines and spirits and specialist foods
- Due to the high stiffness of the facestock we do not recommend this construction for small diameter substrates (neck labels)
- Can be further embellished using foil stamping and embossing
- High levels of embossing could impair the moisture barrier and reduce adhesion/mandrel performance
- Labels must have a 3mm grain free zone measured from label edges
- Not recommended for neck labels or tight mandrel applications due to high stiffness
- Not available with removable or repositionable adhesives
- The use of over-varnish is essential to enhance surface water repellance

- Refer to Wine Technical Brochure for more PS application considerations

Printing & Converting

- Printable by all conventional printing techniques
- Due to open and textured nature of the face material, best results are in general from those techniques with maximum conformability of printing plate such as flexo and offset
- Excellent results, in line with desired image, using offset or screen
- Maximum temperatures used 80°C for ink drying and 50°C for the waste stripping

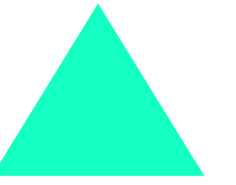

Basis Weight
110 g/m²

Thickness
120 µm

Print Technology

Conventional Press
✓

VI
-

Print Performance

Printability
●●●●●

Stiffness
●●●●●

Print Definition
●●●●●

Conformability
●○○○○

Print Durability
●●●●●

OBA

Tensile Strength

Wet Opacity
●●●●○

Water Resistance

Dry Opacity
●●●●○

Artisan rPLUS FSC

A white uncoated matt wood-free printing paper, with a felt marked finish, giving the paper a tactile “hand made” appearance and feel

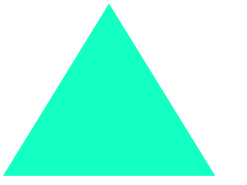

Basis Weight
124 g/m²

Thickness
156 µm

Applications

Wine & spirits, high end food and beverage packaging

Features

- FSC Certified
- Under-laminated rPET with 25% recycled content to assist with reducing bubbles and wrinkles and maintain structure in an ice bucket
- Features wet strength properties which assist in retaining the strength of the paper fibres when exposed to moisture or wet environments
- Polymer underlamine improves moisture barrier properties and reduces the severity of paper fibre swelling induced “bubbling” on difficult substrates
- Not recommended for neck labels or tight mandrel applications due to high stiffness
- Not available with removable or repositionable adhesives

Printing & Converting

- Printable using all conventional label printing processes, however the textured nature of the facestock means that it is better suited to offset printing
- Can be further embellished using foil stamping and embossing
- High levels of embossing could impair the moisture barrier and reduce adhesion / mandrel performance
- Labels must have a 3mm grain free zone measured from label edges
- Suitable for conventional die-cutting processes, contact your die-consultant for details
- Suitable for conventional inks and varnishes, contact your ink specialist for details
- The use of over-varnish is essential to enhance surface water repellency
- Refer to Wine Technical Brochure for more PS application considerations

Print Technology

Conventional Press
✓

VI
-

Print Performance

Printability
●●●●○

Stiffness
●●●●○

Print Definition
●●●●○

Conformability
●●○○○

Print Durability
●●●●○

OBA
✓

Tensile Strength

Wet Opacity
●●●●○

Water Resistance

Dry Opacity
●●●●●

Artisan FSC

A white uncoated matt wood-free printing paper, with a felt marked finish, giving the paper a tactile “hand made” appearance and feel

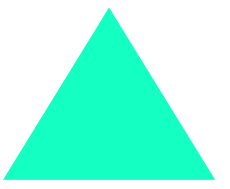

Basis Weight
95 g/m²

Thickness
135 µm

Applications

Wine & spirits, high end food and beverage packaging

Features

- FSC Certified
- Features wet strength properties which assist in retaining the strength of the paper fibres when exposed to moisture or wet environments
- Not recommended for neck labels or tight mandrel applications due to high stiffness
- Not available with removable or repositionable adhesives

Printing & Converting

- Printable using all conventional label printing processes, however the textured nature of the facestock means that it is better suited to offset printing
- Can be further embellished using foil stamping and embossing
- High levels of embossing could impair the moisture barrier and reduce adhesion / mandrel performance
- Labels must have a 3mm grain free zone measured from label edges
- Suitable for conventional die-cutting processes, contact your die-consultant for details
- Suitable for conventional inks and varnishes, contact your ink specialist for details
- The use of over-varnish is essential to enhance surface water repellency
- Refer to Wine Technical Brochure for more PS application considerations

Print Technology

Conventional Press
✓

VI
-

Print Performance

Printability
●●●●○

Stiffness
●●●●○

Print Definition
●●●●○

Conformability
●●○○○

Print Durability
●●●●○

OBA
✓

Tensile Strength

Wet Opacity
●●●●○

Water Resistance

Dry Opacity
●●●●●

ARCTIC rPLUS FSC

A high white, uncoated, matt, felt marked wood-free printing paper. Under-laminated rPET with 25% recycled content to assist with reducing bubbles and wrinkles and maintain structure in an ice bucket. Wet strength and fungicidal treatment. The facestock is made from FSC certified paper

Applications

Wine & spirits, high end food and beverage packaging

Features

- FSC Certified
- Features wet strength and fungicidal properties which assist in retaining the strength of the paper fibres when exposed to moisture or wet environments
- Polymer underlamine improves moisture barrier properties and reduces the severity of paper fibre swelling induced “bubbling” on difficult substrates
- Not recommended for neck labels or tight mandrel applications due to high stiffness
- Not available with removable or repositionable adhesives

Printing & Converting

- Printable using all conventional label printing processes, however the textured nature of the facestock means that it is better suited to offset printing
- Can be further embellished using foil stamping and embossing. High levels of embossing could reduce adhesion/mandrel performance
- Labels must have a 3mm grain free zone measured from label edges
- This product is not recommended for applications where labels are exposed to direct sunlight or temperatures above 50°C
- Not recommended for neck labels or tight mandrel applications due to high stiffness
- The use of over-varnish is essential to enhance surface water repellency
- Refer to Wine Technical Brochure for more PS application considerations

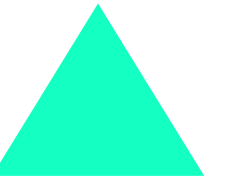

Basis Weight

125 g/m²

Thickness

155 µm

Print Technology

Conventional Press



VI



Print Performance

Printability



Stiffness



Print Definition



Conformability



Print Durability



OBA

Tensile Strength

Wet Opacity



Water Resistance

Dry Opacity



AF101

Permanent • Emulsion Acrylic

Film

Specific Applications

Food, beverage, cosmetics, household, promotional, industrial, pharmaceutical

Features

- All temperature adhesive providing high initial tack and excellent adhesion to a wide variety of substrates
- Exhibits low bleed characteristics
- Good die cutting & guillotining properties.

Initial Tack
High

Ultimate Adhesion
High

Min. App. Temp.
7°C

Service Temp.
-50°C to 90°C

Substrates

Test	Cardboard	✓	PP
✓	PET	✓	Glass
✓	HDPE	✓	PVC
✓	LDPE	✓	Rigid PS

Applications

-	Freezer	Test	Tight Mandrel
✓	Chilled	Test	Ice Bucket
-	Wet Surfaces		

Food Compliance

✓	Indirect	-	Direct
---	----------	---	--------

AP103

Permanent • Emulsion Acrylic

Paper

Specific Applications

Food, beverage, cosmetics, household, promotional, industrial, pharmaceutical

Features

- All temperature adhesive providing high initial tack and excellent adhesion to a wide variety of substrates
- Exhibits low bleed characteristics
- Good die cutting & guillotining properties

Initial Tack
Very High

Ultimate Adhesion
Very High

Min. App. Temp.
7°C

Service Temp.
-50°C to 90°C

Substrates

- | | |
|-------------|------------|
| ✓ Cardboard | ✓ PP |
| ✓ PET | ✓ Glass |
| ✓ HDPE | ✓ PVC |
| ✓ LDPE | ✓ Rigid PS |

Applications

- | | |
|----------------|--------------------|
| - Freezer | Test Tight Mandrel |
| - Chilled | - Ice Bucket |
| - Wet Surfaces | |

Food Compliance

- | | |
|------------|----------|
| ✓ Indirect | - Direct |
|------------|----------|

rET9MB

Permanent • Emulsion Acrylic

Paper

Specific Applications

Food, beverage, cosmetics, household, promotional, industrial, pharmaceutical

Features

- Excellent initial tack and adhesion on a variety of substrates
- Exhibits low bleed characteristics
- Good die-cutting and stripping properties
- Offers a wide service temperature range
- Demonstrates good UV resistance

Initial Tack
Medium

Ultimate Adhesion
High

Min. App. Temp.
5°C

Service Temp.
-20°C to 100°C

Substrates

Test	Cardboard	✓	PP
✓	PET	✓	Glass
✓	HDPE	✓	PVC
✓	LDPE	✓	Rigid PS

Applications

-	Freezer	Test	Tight Mandrel
-	Chilled	-	Ice Bucket
-	Wet Surfaces		

Food Compliance

✓	Indirect	-	Direct
---	----------	---	--------

SR3013

Permanent • Emulsion Acrylic

Film

Specific Applications

Predominantly in beverage, food and HPC market segment where PET bottles and PET containers are used.

Features

- Designed specifically for labeling and recycling of PET bottles and PET containers
- Developed to provide high initial tack and excellent adhesion
- Displays excellent die-cutting and stripping characteristics.

Initial Tack
High

Ultimate Adhesion
High

Min. App. Temp.
5°C

Service Temp.
-20°C to 80°C

Substrates

- | | |
|-------------|------------|
| - Cardboard | ✓ PP |
| ✓ PET | ✓ Glass |
| ✓ HDPE | ✓ PVC |
| ✓ LDPE | ✓ Rigid PS |

Applications

- | | |
|----------------|-----------------|
| - Freezer | ✓ Tight Mandrel |
| ✓ Chilled | - Ice Bucket |
| - Wet Surfaces | |

Food Compliance

- | | |
|------------|----------|
| ✓ Indirect | - Direct |
|------------|----------|

S2045

Permanent • Rubber Based Hotmelt

Paper/Film

Specific Applications

Food, beverage, cosmetics, household, promotional, industrial, pharmaceutical

Features

- Global adhesive exhibiting very good tack and adhesion on a wide variety of substrates, including apolar, slightly rough and curved substrates
- Particularly good performance at lower temperatures, e.g. labeling of chilled products.

Initial Tack
High

Ultimate Adhesion
High

Min. App. Temp.
0°C

Service Temp.
-40°C to 70°C

Substrates

Test	Cardboard	✓	PP
✓	PET	✓	Glass
✓	HDPE	-	PVC
✓	LDPE	✓	Rigid PS

Applications

-	Freezer	Test	Tight Mandrel
Test	Chilled	-	Ice Bucket
-	Wet Surfaces		

Food Compliance

✓	Indirect	✓	Direct
---	----------	---	--------

S2045N

Permanent • Rubber Based Hotmelt

Paper/Film

Specific Applications

Food, beverage, cosmetics, household, promotional, industrial, pharmaceutical

Features

- Global adhesive exhibiting excellent tack and adhesion on a wide variety of substrates, including apolar, slightly rough and curved substrates
- Particularly good performance at lower temperatures, e.g. labeling of chilled products.

Initial Tack
High

Ultimate Adhesion
Very High

Min. App. Temp.
0°C

Service Temp.
-40°C to 70°C

Substrates

- | | |
|-------------|------------|
| ✓ Cardboard | ✓ PP |
| ✓ PET | ✓ Glass |
| ✓ HDPE | - PVC |
| ✓ LDPE | ✓ Rigid PS |

Applications

- | | |
|----------------|--------------------|
| - Freezer | Test Tight Mandrel |
| Test Chilled | - Ice Bucket |
| - Wet Surfaces | |

Food Compliance

- | | |
|------------|----------|
| ✓ Indirect | ✓ Direct |
|------------|----------|

S2049

Permanent • Rubber Based Hotmelt

Paper

Specific Applications

Logistics, track and trace, food, promotional, industrial

Features

- Exhibits excellent adhesive performance
- Ideal for textured HDPE recycled corrugated cardboard and difficult substrates
- Suitable for use under chilled or general purpose temperatures
- Provides moisture resistance after application on a dry surface
- Suitable for a wide variety of substrates including apolar slightly rough and curved surfaces
- Care should be taken where incidental chemical exposure could degrade adhesive performance
- Excessive exposure to sunlight may also result in degradation of the adhesive

Initial Tack
Very High

Ultimate Adhesion
Very High

Min. App. Temp.
0°C

Service Temp.
-40°C to 70°C

Substrates

- | | |
|-------------|------------|
| ✓ Cardboard | ✓ PP |
| ✓ PET | ✓ Glass |
| ✓ HDPE | - PVC |
| ✓ LDPE | ✓ Rigid PS |

Applications

- | | |
|-----------|-----------------|
| - Freezer | ✓ Tight Mandrel |
| ✓ Chilled | - Ice Bucket |

Test Wet Surfaces

Food Compliance

- | | |
|------------|----------|
| ✓ Indirect | ✓ Direct |
|------------|----------|

S2090

Permanent • Emulsion Acrylic

Paper

Specific Applications

Logistics, track and trace, food, promotional, industrial

Features

- High initial tack with excellent adhesion properties
- Good die cutting and stripping properties
- Excellent adhesion to a wide range of substrates, e.g. HDPE, recycled corrugated cardboard and difficult substrates
- Suitable for use on rough surfaces, such as recycled board

Initial Tack
Very High

Ultimate Adhesion
Very High

Min. App. Temp.
5°C

Service Temp.
-20°C to 80°C

Substrates

- | | |
|-------------|------------|
| ✓ Cardboard | ✓ PP |
| ✓ PET | ✓ Glass |
| ✓ HDPE | ✓ PVC |
| ✓ LDPE | ✓ Rigid PS |

Applications

- | | |
|----------------|--------------------|
| - Freezer | Test Tight Mandrel |
| ✓ Chilled | - Ice Bucket |
| - Wet Surfaces | |

Food Compliance

- | | |
|------------|----------|
| ✓ Indirect | - Direct |
|------------|----------|

S4700

Permanent • Emulsion Acrylic

Film

Specific Applications

Cosmetics, toiletries, luxury items, promotional, lubricant oil, household chemical

Features

- Predominantly used in cosmetics, toiletries and luxury items
- Also used for promotional labelling, as well as lubricant and household chemical labels where durability and resistance to moisture is required

Initial Tack
High

Ultimate Adhesion
High

Min. App. Temp.
5°C

Service Temp.
-20°C to 80°C

Substrates

- | | |
|-------------|------------|
| - Cardboard | ✓ PP |
| ✓ PET | ✓ Glass |
| ✓ HDPE | ✓ PVC |
| Test LDPE | ✓ Rigid PS |

Applications

- | | |
|----------------|--------------------|
| - Freezer | Test Tight Mandrel |
| - Chilled | - Ice Bucket |
| - Wet Surfaces | |

Food Compliance

- | | |
|------------|----------|
| ✓ Indirect | - Direct |
|------------|----------|

S692N

Permanent • Emulsion Acrylic

Film

Specific Applications

Cosmetics, personal care and beverages.

Features

- High degree of clarity and “wet out” for clear filmic facestocks
- Good initial tack and adhesion on a variety of substrates including apolar surfaces
- Exhibits low bleed characteristics
- Good die-cutting and stripping properties
- Offers a wide service temperature range
- Demonstrates good UV resistance
- Limited resistance to plasticisers found in PVC substrates and low molecular weight oils

Initial Tack
High

Ultimate Adhesion
High

Min. App. Temp.
5°C

Service Temp.
-20°C to 80°C

Substrates

- | | |
|-------------|------------|
| - Cardboard | ✓ PP |
| ✓ PET | ✓ Glass |
| ✓ HDPE | ✓ PVC |
| ✓ LDPE | ✓ Rigid PS |

Applications

- | | |
|----------------|-----------------|
| - Freezer | ✓ Tight Mandrel |
| ✓ Chilled | - Ice Bucket |
| - Wet Surfaces | |

Food Compliance

- | | |
|------------|----------|
| ✓ Indirect | - Direct |
|------------|----------|

LP430

Permanent • Emulsion Acrylic

Paper

Specific Applications

Household, promotional, industrial

Features

- Exhibits low bleed characteristics
- Displays excellent die cutting and stripping characteristics
- Adhesive designed for use in laser and inkjet printers
- Adhesion to a wide variety of substrates

Initial Tack
High

Ultimate Adhesion
High

Min. App. Temp.
-4°C

Service Temp.
-40 to 93°C

Substrates

Test	Cardboard	✓	PP
✓	PET	✓	Glass
✓	HDPE	✓	PVC
✓	LDPE	✓	Rigid PS

Applications

-	Freezer	Test	Tight Mandrel
-	Chilled	-	Ice Bucket
-	Wet Surfaces		

Food Compliance

-	Indirect	-	Direct
---	----------	---	--------

C2075

Permanent • Rubber Based Hotmelt

Paper/Film

Specific Applications

Freezer/Cold temperature applications, logistics, food

Features

- Excellent cold temperature performance but moderate room temperature performance
- Good adhesion performance can be achieved on slightly frosted surfaces
- Resistant to moisture during thawing
- Suitable for a wide variety of packaging materials and in particular flexible films

Initial Tack
High

Ultimate Adhesion
High

Min. App. Temp.
-20°C

Service Temp.
-50°C to 70°C

Substrates

- | | |
|-------------|------------|
| ✓ Cardboard | ✓ PP |
| ✓ PET | ✓ Glass |
| ✓ HDPE | ✓ PVC |
| ✓ LDPE | ✓ Rigid PS |

Applications

- | | |
|-----------|-----------------|
| ✓ Freezer | - Tight Mandrel |
| ✓ Chilled | - Ice Bucket |

Test Wet Surfaces

Food Compliance

- | | |
|------------|----------|
| ✓ Indirect | ✓ Direct |
|------------|----------|

CD303

Permanent • Emulsion Acrylic

Film

Specific Applications

Durable applications. product identification tags, asset tags, durable goods labeling

Features

- Aggressive tack provides an extremely strong bond for demanding applications
- This adhesive is suited for outdoor applications
- Suitable for adhering to rough surfaces including HDPE chemical drums
- The construction will have a tendency to bleed, so therefore avoid tight rewinding

Initial Tack
Very High

Ultimate Adhesion
Very High

Min. App. Temp.
0°C

Service Temp.
-30°C to 70°C

Substrates

- | | |
|-------------|------------|
| ✓ Cardboard | ✓ PP |
| ✓ PET | ✓ Glass |
| ✓ HDPE | ✓ PVC |
| ✓ LDPE | ✓ Rigid PS |

Applications

- | | |
|----------------|-----------------|
| - Freezer | - Tight Mandrel |
| ✓ Chilled | - Ice Bucket |
| ✓ Wet Surfaces | |

Food Compliance

- | | |
|------------|----------|
| ✓ Indirect | - Direct |
|------------|----------|

S2012HT

Permanent • Emulsion Acrylic

Paper

Specific Applications

Laser, sheets

Features

- Designed for roll to sheet conversion
- Suitable for copier and laser printer products
- Features excellent guillotining properties with reduced edge bleed
- Good tack and adhesion performance subject to surface conditions
- Offers performance over a wide temperature range
- High speed sheet fed laser printers and copiers
- Not recommended for moist environments

Initial Tack
High

Ultimate Adhesion
High

Min. App. Temp.
0°C

Service Temp.
-20°C to 80°C

Substrates

Test Cardboard

Test PP

✓ PET

Test Glass

Test HDPE

✓ PVC

Test LDPE

Test Rigid PS

Applications

- Freezer

- Tight Mandrel

- Chilled

- Ice Bucket

- Wet Surfaces

Food Compliance

✓ Indirect

- Direct

S2660

Permanent • Emulsion Acrylic

Paper

Specific Applications

Food, beverage, cosmetics, household, promotional, industrial, pharmaceutical

Features

- Ideal for high speed conversion and production of complex shaped labels
- Combines high initial tack with excellent adhesion properties on a wide range of substrates
- Excellent UV and ageing resistance
- Recommended for curved substrates e.g. small diameter glass ampoules
- Complies with FDA 175.105 and with BgVV XIV recommendations for indirect contact with foodstuff

Initial Tack
High

Ultimate Adhesion
Very High

Min. App. Temp.
5°C

Service Temp.
-20°C to 80°C

Substrates

- | | |
|-------------|------------|
| - Cardboard | ✓ PP |
| ✓ PET | ✓ Glass |
| ✓ HDPE | ✓ PVC |
| ✓ LDPE | ✓ Rigid PS |

Applications

- | | |
|----------------|--------------------|
| - Freezer | Test Tight Mandrel |
| - Chilled | - Ice Bucket |
| - Wet Surfaces | |

Food Compliance

- | | |
|------------|----------|
| - Indirect | - Direct |
|------------|----------|

S333

Permanent • Emulsion Acrylic

Film

Specific Applications

Durable applications. product identification tags, asset tags, durable goods labeling

Features

- High degree of clarity and “wet out” for clear filmic facestocks
- Good initial tack and adhesion on a variety of substrates including apolar surfaces
- Exhibits low bleed characteristics
- Good die-cutting and stripping properties
- Offers a wide service temperature range include high temp durable performance
- Demonstrates good UV resistance
- Durable application adhesive
- Adhesive available on imported laminates only

Initial Tack
High

Ultimate Adhesion
High

Min. App. Temp.
-4°C

Service Temp.
-40°C to
148°C

Substrates

- | | |
|-------------|------------|
| - Cardboard | ✓ PP |
| ✓ PET | ✓ Glass |
| ✓ HDPE | ✓ PVC |
| ✓ LDPE | ✓ Rigid PS |

Applications

- | | |
|----------------|-----------------|
| - Freezer | ✓ Tight Mandrel |
| ✓ Chilled | - Ice Bucket |
| - Wet Surfaces | |

Food Compliance

- | | |
|------------|----------|
| - Indirect | - Direct |
|------------|----------|

S7400

Permanent • Emulsion Acrylic

Film

Specific Applications

Glass substrates, food, beer and beverage

Features

- Designed specifically for prime film beer and beverage label applications which require resistance to water
- It is engineered to be applied in moist environments typically found in brewery (beer) applications
- Maintains clarity even with extended exposure to ice water after the label has been applied to a dry surface
- This adhesive offers improved release for both matrix stripping and dispensing
- It also has excellent wetout characteristics.

Initial Tack
Medium

Ultimate Adhesion
High

Min. App. Temp.
-4°C

Service Temp.
-40°C to 80°C

Substrates

- | | |
|-------------|------------|
| ✓ Cardboard | ✓ PP |
| ✓ PET | ✓ Glass |
| ✓ HDPE | - PVC |
| ✓ LDPE | ✓ Rigid PS |

Applications

- | | |
|----------------|-----------------|
| - Freezer | ✓ Tight Mandrel |
| ✓ Chilled | ✓ Ice Bucket |
| ✓ Wet Surfaces | |

Food Compliance

- | | |
|------------|----------|
| ✓ Indirect | - Direct |
|------------|----------|

SPX

Permanent • Rubber Based Hotmelt

Film

Specific Applications

Food, beverage, cosmetics, household, promotional, industrial

Features

- Use in chilled dairy applications for textured HDPE containers
- Designed for use with filmic facestocks
- Moisture resistant
- Commonly adopted for industrial and chilled applications
- High adhesion and tack to apolar surfaces

Initial Tack
Very High

Ultimate Adhesion
Very High

Min. App. Temp.
-5°C

Service Temp.
-40°C to 70°C

Substrates

- | | |
|-------------|------------|
| ✓ Cardboard | ✓ PP |
| ✓ PET | ✓ Glass |
| ✓ HDPE | - PVC |
| ✓ LDPE | ✓ Rigid PS |

Applications

- | | |
|----------------|-----------------|
| - Freezer | ✓ Tight Mandrel |
| ✓ Chilled | - Ice Bucket |
| - Wet Surfaces | |

Food Compliance

- | | |
|------------|----------|
| - Indirect | - Direct |
|------------|----------|

TS79

Permanent • Rubber Based Hotmelt

Paper/Film

Specific Applications

Tyre

Features

- TS79 is specially designed to meet the performance requirements of automotive tyre labelling
- The special composition provides a superb anchorage of the label to the compound curved and extremely irregular surface of tyres, neglecting the negative influences of surface contaminants such as mould release agents or components migrating from the rubber
- Temperature levels of 50 degrees celsius should not be exceeded
- Excessive exposure to sunlight may also result in degradation of the adhesive
- This label material does not have any negative effect on the properties and performance of labelled tyres
- Limited conversion speeds
- The construction will have a tendency to bleed, so therefore avoid tight rewinding

Note: this product contains a very aggressive adhesive. If the product is without SGP (Special Gum Pattern), slit reels will not be delivered with bleed-free edges and edge-bleed can occur. In case bleed-free edges are required, please contact your local sales representative.

Initial Tack
Very High

Ultimate Adhesion
Very High

Min. App. Temp.
0°C

Service Temp.
-20°C to 70°C

Substrates

- | | |
|-------------|------------|
| ✓ Cardboard | ✓ PP |
| ✓ PET | ✓ Glass |
| ✓ HDPE | ✓ PVC |
| Test LDPE | ✓ Rigid PS |

Applications

- | | |
|----------------|--------------------|
| - Freezer | Test Tight Mandrel |
| Test Chilled | - Ice Bucket |
| - Wet Surfaces | |

Food Compliance

- | | |
|------------|----------|
| - Indirect | - Direct |
|------------|----------|

AT20

Cold temperature • Emulsion Acrylic

Paper

Specific Applications

Freezer/Cold temperature applications

Features

- Excellent cold temperature performance
- Moderate room temperature performance
- Suitable for a wide variety of packaging materials and in particular flexible films
- Good die cutting and stripping properties
- An all temperature adhesive with moderate adhesion performance at room temperature

Initial Tack
Medium

Ultimate Adhesion
Medium

Min. App. Temp.
-40°C

Service Temp.
-50°C to 90°C

Substrates

- | | |
|-------------|------------|
| ✓ Cardboard | ✓ PP |
| ✓ PET | ✓ Glass |
| ✓ HDPE | ✓ PVC |
| ✓ LDPE | ✓ Rigid PS |

Applications

- | | |
|----------------|-----------------|
| Test Freezer | ✓ Tight Mandrel |
| ✓ Chilled | ✓ Ice Bucket |
| ✓ Wet Surfaces | |

Food Compliance

- | | |
|------------|----------|
| ✓ Indirect | - Direct |
|------------|----------|

rS2030MB

Permanent • Emulsion Acrylic

Paper

Specific Applications

Wine

Features

- Provides excellent die cutting and stripping properties
- Recommended for difficult label shapes and high speed conversion
- Very good mandrel performance
- The product is designed for use in the beverage industry, when the advantages of front & back body labels and neck / shoulder labelling on the same adhesive is important
- Adhesive performance will be reduced if heavy embossing or foiling is applied
- Prior testing is strongly recommended. Labels must have a 3mm grain free zone measured from label edges
- To avoid bubbling with offset papers care needs to be taken with application. Refer to Water Spray Protocol in the Avery Dennison Wine Technical Handbook

Initial Tack
Very High

Ultimate Adhesion
Very High

Min. App. Temp.
5°C

Service Temp.
-20°C to 80°C

Substrates

Test	Cardboard	✓	PP
✓	PET	✓	Glass
✓	HDPE	-	PVC
✓	LDPE	✓	Rigid PS

Applications

-	Freezer	✓	Tight Mandrel
✓	Chilled	✓	Ice Bucket

Test Wet Surfaces

Food Compliance

✓	Indirect	-	Direct
---	----------	---	--------

S2047

Permanent • Rubber Based Hotmelt

Paper

Specific Applications

Wine

Features

- Provides high tack and adhesion on difficult bottle surfaces
- Provides moisture resistance after application on a dry surface
- Suitable for low temperature application
- Excellent ice bucket resistance
- Adhesive performance will be reduced if heavy embossing or foiling is applied
- Prior testing is strongly recommended. Labels must have a 3mm grain free zone measured from label edges
- To avoid bubbling with offset papers care needs to be taken with application. Refer to Water Spray Protocol Technical Marketing Bulletin
- For details on ice bucket performance please refer to the Avery Dennison Wine Technical Handbook
- Excessive exposure to sunlight may also result in degradation of the adhesive

Initial Tack
Very High

Ultimate Adhesion
Very High

Min. App. Temp.
0°C

Service Temp.
-40°C to 70°C

Substrates

- | | |
|-------------|------------|
| ✓ Cardboard | ✓ PP |
| ✓ PET | ✓ Glass |
| ✓ HDPE | ✓ PVC |
| ✓ LDPE | ✓ Rigid PS |

Applications

- | | |
|----------------|-----------------|
| - Freezer | ✓ Tight Mandrel |
| ✓ Chilled | ✓ Ice Bucket |
| ✓ Wet Surfaces | |

Food Compliance

- | | |
|------------|----------|
| ✓ Indirect | ✓ Direct |
|------------|----------|

S3037

Permanent • Rubber Based Hotmelt

Paper

Specific Applications

Wine

Features

- Provides high tack and adhesion on difficult bottle surfaces
- Provides moisture resistance after application on a dry surface
- Suitable for low temperature application
- Excellent ice bucket resistance
- Adhesive performance will be reduced if heavy embossing or foiling is applied
- Prior testing is strongly recommended. Labels must have a 3mm grain free zone measured from label edges
- To avoid bubbling with offset papers care needs to be taken with application. Refer to Water Spray Protocol Technical Marketing Bulletin
- For details on ice bucket performance please refer to the Avery Dennison Wine Technical Handbook
- Excessive exposure to sunlight may also result in degradation of the adhesive

Initial Tack
Very High

Ultimate Adhesion
Very High

Min. App. Temp.
0°C

Service Temp.
-40°C to 70°C

Substrates

- | | |
|-------------|------------|
| ✓ Cardboard | ✓ PP |
| ✓ PET | ✓ Glass |
| ✓ HDPE | ✓ PVC |
| ✓ LDPE | ✓ Rigid PS |

Applications

- | | |
|-----------|-----------------|
| - Freezer | ✓ Tight Mandrel |
| ✓ Chilled | ✓ Ice Bucket |

Test **Wet Surfaces**

Food Compliance

- | | |
|------------|----------|
| ✓ Indirect | ✓ Direct |
|------------|----------|

WLK202

Permanent • Emulsion Acrylic

Paper

Specific Applications

Wine

Features

- Very aggressive wine adhesive exhibiting excellent adhesive performance
- For use in difficult applications where moderate levels of moisture are present eg. sparkling wine
- Offers good ice bucket performance when used with appropriate varnished facestocks
- Effective during extended storage in refrigeration
- Suitable for neck labelling applications when matched with low memory facestocks
- Adhesive performance will be reduced if heavy embossing or foiling is applied
- Prior testing is strongly recommended
- Labels must have a 3mm grain free zone measured from label edges
- Where high levels of moisture are present it is recommended in-line air blowers are used prior to application
- The construction will have a tendency to bleed, so therefore avoid tight rewinding
- For details on ice bucket performance please refer to the Technical Marketing Bulletin

Initial Tack
Very High

Ultimate Adhesion
Very High

Min. App. Temp.
0°C

Service Temp.
-30°C to 80°C

Substrates

- | | |
|-------------|------------|
| ✓ Cardboard | ✓ PP |
| ✓ PET | ✓ Glass |
| ✓ HDPE | - PVC |
| ✓ LDPE | ✓ Rigid PS |

Applications

- | | |
|-----------|-----------------|
| - Freezer | ✓ Tight Mandrel |
| ✓ Chilled | ✓ Ice Bucket |

Test **Wet Surfaces**

Food Compliance

- | | |
|------------|----------|
| ✓ Indirect | - Direct |
|------------|----------|

Z1010

Permanent • Emulsion Acrylic

Paper

Specific Applications

Wine

Features

- A patented adhesive engineered to help minimise the loss of opacity in wet conditions (grey effect), without sacrificing diecutting and stripping properties. It is particularly well-suited for white and blush wines, champagne, and beer applications, due to its intended exposure to ice bucket conditions. The adhesive features high initial tack, excellent adhesion and good low temperature performance on a wide variety of substrates
- Specially designed for wine labelling applications it allows easy conversion of difficult label shapes.

Initial Tack
High

Ultimate Adhesion
Very High

Min. App. Temp.
5°C

Service Temp.
-20°C to 60°C

Substrates

Test	Cardboard	✓	PP
✓	PET	✓	Glass
✓	HDPE	-	PVC
✓	LDPE	✓	Rigid PS

Applications

-	Freezer	Test	Tight Mandrel
✓	Chilled	✓	Ice Bucket
✓	Wet Surfaces		

Food Compliance

✓	Indirect	-	Direct
---	----------	---	--------

R100

Removable • Rubber Based Solvent

Paper

Specific Applications

Paper, greeting cards, aluminium, stainless steel and glass

Features

- Features good tack and adhesion performance
- Offers excellent clean long term removability
- The adhesive allows label application at a wide temperature range
- Please note removable adhesives are not recommended for tight mandrel applications
- Removability is subject to surface conditions, Avery Dennison recommends trialing before use
- removes clean from many substrates such as polymeric (PET, PP, ABS, PS), greeting cards, aluminium, stainless steel and glass (not suitable for window labelling)
- Application to porous substrates such as paper and board, or prolonged exposure to UV light may adversely affect clean removability

Initial Tack
Medium

Ultimate Adhesion
Medium

Min. App. Temp.
- 20°C

Service Temp.
-40°C to 80°C

Substrates

- | | |
|-------------|------------|
| ✓ Cardboard | ✓ PP |
| ✓ PET | ✓ Glass |
| ✓ HDPE | - PVC |
| ✓ LDPE | - Rigid PS |

Applications

- | | |
|----------------|-----------------|
| Test Freezer | - Tight Mandrel |
| ✓ Chilled | - Ice Bucket |
| - Wet Surfaces | |

Food Compliance

- | | |
|------------|----------|
| - Indirect | - Direct |
|------------|----------|

R5000

Removable • Emulsion Acrylic

Paper/Film

Specific Applications

General Purpose, retail, promotion, pharmaceutical

Features

- Features good tack and adhesion performance
- Offers relatively long term removability in combination with superior and clean removability from most substrates
- Delivers good UV resistance
- The adhesive allows label application at a wide temperature range and it retains its removable properties even at very low temperatures
- The adhesive complies with the European food directives and legislations, FDA 175.105 and the German recommendations XIV as published by BfR. BfR (Bundesinstitut für Risikobewertung) is the German Federal Institute for Risk Assessment. The adhesive can be used in direct contact with dry and moist, non fatty foodstuffs
- Please note removable adhesives are not recommended for tight mandrel applications
- Removability is subject to surface conditions, Avery Dennison recommends trialing before use

Initial Tack
Low

Ultimate Adhesion
Medium

Min. App. Temp.
- 5°C

Service Temp.
-30°C to 80°C

Substrates

- | | |
|-------------|------------|
| ✓ Cardboard | ✓ PP |
| - PET | ✓ Glass |
| ✓ HDPE | - PVC |
| ✓ LDPE | ✓ Rigid PS |

Applications

- | | |
|----------------|-----------------|
| - Freezer | - Tight Mandrel |
| Test Chilled | - Ice Bucket |
| - Wet Surfaces | |

Food Compliance

- | | |
|------------|----------|
| ✓ Indirect | ✓ Direct |
|------------|----------|

SR2

Removable • Emulsion Acrylic

Film

Specific Applications

General Purpose, retail, promotion, pharmaceutical

Features

- Features good tack and adhesion performance
- Offers clean medium term removability
- Delivers good UV resistance
- The adhesive allows label application at a wide temperature range
- Please note removable adhesives are not recommended for tight mandrel applications
- Removability is subject to surface conditions, Avery Dennison recommends trialing before use
- This adhesive is not recommended for cardboard

Initial Tack
Medium

Ultimate Adhesion
Medium

Min. App. Temp.
- 5°C

Service Temp.
-30°C to 60°C

Substrates

- | | |
|-------------|------------|
| - Cardboard | ✓ PP |
| - PET | ✓ Glass |
| ✓ HDPE | - PVC |
| ✓ LDPE | - Rigid PS |

Applications

- | | |
|----------------|-----------------|
| Test Freezer | - Tight Mandrel |
| ✓ Chilled | - Ice Bucket |
| - Wet Surfaces | |

Food Compliance

- | | |
|------------|----------|
| - Indirect | - Direct |
|------------|----------|

UVR145

Removable • Emulsion Acrylic

Film

Specific Applications

Reclosure, Cosmetics, household, promotional, industrial, pharmaceutical

Features

- Good tack and adhesive performance
- Clean removability
- Specially designed for glass applications
- Please note: removable adhesives are not recommended for tight mandrels
- Removability is subject to surface conditions
- Clean removability from glass surfaces
- On a few substrates (a.o. PVC, Polystyrene and ABS) the adhesion tends to become higher over time
- Avery Dennison recommends trialing before use

Initial Tack
Medium

Ultimate Adhesion
Medium

Min. App. Temp.
5°C

Service Temp.
-20°C to 80°C

Substrates

- | | |
|-------------|------------|
| ✓ Cardboard | ✓ PP |
| ✓ PET | ✓ Glass |
| ✓ HDPE | Test PVC |
| ✓ LDPE | - Rigid PS |

Applications

- | | |
|----------------|-----------------|
| - Freezer | - Tight Mandrel |
| ✓ Chilled | - Ice Bucket |
| - Wet Surfaces | |

Food Compliance

- | | |
|------------|----------|
| - Indirect | - Direct |
|------------|----------|

LR2N

Removable • Emulsion Acrylic

Paper

Specific Applications

Laser printers and copiers, sheets

Features

- Designed for VI printer products, e.g. for laserprinters and copiers
- Features good tack and adhesion performance
- Offers clean long term removability
- Delivers good UV resistance
- The adhesive allows label application at a wide temperature range
- The adhesive complies with the USA food directive and legislation FDA 175.105
- Please note: removable adhesives are not recommended for tight mandrel applications
- Removability is subject to surface conditions, Avery Dennison recommends trialing before use
- This adhesive is not recommended for cardboard

Initial Tack
Low

Ultimate Adhesion
Low

Min. App. Temp.
-15°C

Service Temp.
-30°C to 80°C

Substrates

- | | |
|-------------|------------|
| - Cardboard | ✓ PP |
| ✓ PET | ✓ Glass |
| ✓ HDPE | - PVC |
| - LDPE | ✓ Rigid PS |

Applications

- | | |
|----------------|-----------------|
| Test Freezer | - Tight Mandrel |
| Test Chilled | - Ice Bucket |
| - Wet Surfaces | |

Food Compliance

- | | |
|------------|----------|
| - Indirect | - Direct |
|------------|----------|

BG33 WH N

A white FSC Certified super calendered glassine paper

Basis Weight

50 g/m²

Thickness

45 μm

Features

Designed for medium speed conversion. Good caliper consistency allows accurate kiss die cutting.

BG40 BR

A brown super calendered glassine paper

Basis Weight

62 g/m²

Thickness

56 μm

Features

Designed for medium to high speed conversion. Good caliper consistency allows accurate kiss die cutting.

BG40 WH N

A white super calendered glassinated paper

Basis Weight

59 g/m²

Thickness

53 μm

Features

Designed for medium to high speed conversion. Good caliper consistency allows accurate kiss die cutting. The paper's translucent properties are perfectly suited to automatic label applicators and is particularly suitable for products in reels.

BG40 WH NF

A white FSC certified super calendered glassinated paper

Basis Weight

59 g/m²

Thickness

53 μm

Features

Designed for medium to high speed conversion. Good caliper consistency allows accurate kiss die cutting. The paper's translucent properties are perfectly suited to automatic label applicators and is particularly suitable for products in reels.

BG45 WH

A high strength white super calendered glassinated paper

Basis Weight

72 g/m²

Thickness

63 μm

Features

Specially designed for high speed conversion, sprocket punching and perforations. Good caliper consistency allows accurate kiss die cutting. The paper's translucent properties are perfectly suited to automatic label applicators and is particularly suitable for products in reels and later converting to fan folded labels

PET23 = 0.92M PET

A clear polyester film giving optimum smoothness to the adhesive layer and featuring very high durability

Basis Weight
35 g/m²

Thickness
23 μm

Features

For applications where highest clarity of the applied label is required i.e. the “no label look”.
The films high strength and uniform caliper permit very high speed conversion and dispensing.

PET30 = 1.2M PET

A clear polyester film giving optimum smoothness to the adhesive layer and featuring very high durability

Basis Weight

42 g/m²

Thickness

30 μm

Features

For applications where highest clarity of the applied label is required i.e. the “no label look”.
The films high strength and uniform caliper permit very high speed conversion and dispensing.

rPET23

A clear polyester film giving optimum smoothness to the adhesive layer and featuring very high durability

Basis Weight

33 g/m²

Thickness

23 μm

Features

Designed to provide high strength and uniform quality, permitting very high speed conversion and dispensing with reliability in severe application environments. rPET23 liner is made partially from recycled PET flakes.

rPET30

A clear polyester film giving optimum smoothness to the adhesive layer and featuring very high durability

Basis Weight

43 g/m²

Thickness

30 μm

Features

Designed to provide high strength and uniform quality, permitting very high speed conversion and dispensing with reliability in severe application environments. rPET30 liner is made partially from recycled PET flakes.

B100

A clay coated Kraft liner designed for excellent layflat needed in sheet products

Basis Weight

100 g/m²

Thickness

81 µm

Features

A high strength woodfree kraft paper with good dimensional stability and flatness during processing, combined with the resilience to support die cutting. A clay coating on the unsiliconised side makes this surface suitable for high quality process printing. B100 is ideally suited for high quality printing of descriptive or instructional material on return coupons or give-aways as well as an excellent medium for latex-based “scratch-off” competitions.

CCK

A one side clay coated Kraft liner with good dimensional stability

Basis Weight

58 g/m²

Thickness

55 μm

Features

The Hygroflat liner suitable for high speed sheet fed laser printers and copiers. Suited for roll to sheet label conversion.

50 SCK

A bleached super calendered kraft featuring high internal strength and toughness

Basis Weight

88 g/m²

Thickness

81 μm

Features

Used for standard roll to roll and fan fold applications requiring marginal sprocket punching and perforating. Not recommended for sheeted applications

HF55N

A one side clay coated Kraft liner with good dimensional stability

Basis Weight

58 g/m²

Thickness

55 μm

Features

The Hygroflat liner suitable for the home office and home ink jet printing market. Flatbed, solid and magnetic dies can all be used however all rotary tools should be proofed first for the HF55 liner

HF75

A one side clay coated bleached Kraft liner with good dimensional stability

Basis Weight

76 g/m²

Thickness

76 μm

Features

This high bulk Hygroflat 76 gram liner provides extra stiffness for use in industrial laser printing processes. Ideal for hot laser and copier machines for optimum layflat.

HF80N

A one side clay coated uncalendered Kraft liner with good dimensional stability

Basis Weight

81 g/m²

Thickness



86 μm

Features

The relatively low moisture sensitivity of this backing paper provides stable products under varying conditions. Suitable for fanfold and roll to sheet conversion, and all products requiring good layflat properties.

Adhesive - Plastic Substrate Guide

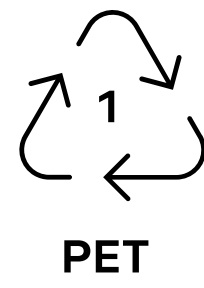
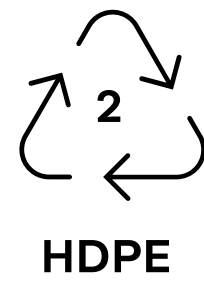
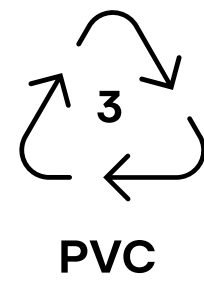
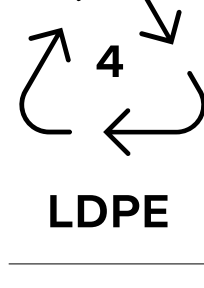
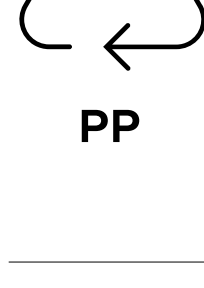
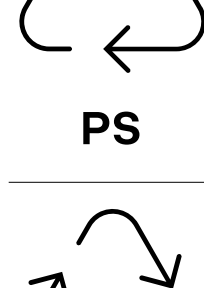
This chart is to be used as a guide. Prior testing is strongly recommended as plastics of the same family can exhibit varying label performance characteristics.

		Permanent					Removable			
		Paper			Synthetics		Paper		Synthetics	
	Soft drink, fruit juice & mineral water bottles some kitchen & laundry detergent bottles	ET9 S2045 S2045N S2047	S3037 S2049 S2030 WLP	WLK202 Z3338 AT20 C2075	S2012HT S2059 CD303 rET9MB	rS2030MB	SPX SRP S692N	S7400 SR3013	R100	
	Milk & cream bottles as well as kitchen laundry & detergent bottles supermarket & retailers bags	ET9 S2045 S2045N S2049	S2047 S3037 S2030 WLP	WLK202 Z3338 AT20 S2059	CD303 D170 rET9MB rS2030MB		SPX SRP S692N	S7400 S4700	R5000 R100	
	Cordial & fruit juice bottles as well as kitchen, laundry & detergent bottles						S692N		R100	
	Shrink & stretch wrap	S2045 S2045N S2047	S3037 S2049 S2030	WLK202 Z3338 AT20	S2059 CD303 D170		SPX SRP S692N	S7400 S4700	R5000 R100	SR2 UVR145
	Ice-cream tubs & food containers	ET9 S2045 S2045N S2047	S3037 S2049 S2030 WLP	WLK202 Z3338 AT20 S2059	CD303 D170 rET9MB rS2030MB		SPX SRP S692N	S7400 S4700	R5000 R100	SR2 UVR145
	Yoghurt containers, jars, take-away "clamshells", fruit boxes	ET9 S2045 S2045N	S2047 S3037 S2049	S2030 WLP WLK202	Z3338 AT20 S2059	CD303 rET9MB rS2030MB	SPX SRP	S692N S7400	R5000 R100	SR2
	Seek advice for items in this category	<p>* Check prior to use. * Refer to your Avery Dennison Representative or call your nearest Sales Office on 1300 369 984 within Australia or on 09 573 0995 in New Zealand.</p>								

Packaging Recyclability

To create sustainable packaging, we must adopt label technologies that reflect a whole systems approach—from materials design to end-use—and work in harmony with the existing recycling stream.

The waste hierarchy

The waste hierarchy is a set of priorities for the efficient use of resources that advances the circular economy. In place of the traditional waste management approach consisting of three Rs (Reduce, Reuse, Recycle), it shows a more elaborate waste management hierarchy – listing actions in order of priority, from least to most favourable from an environmental perspective

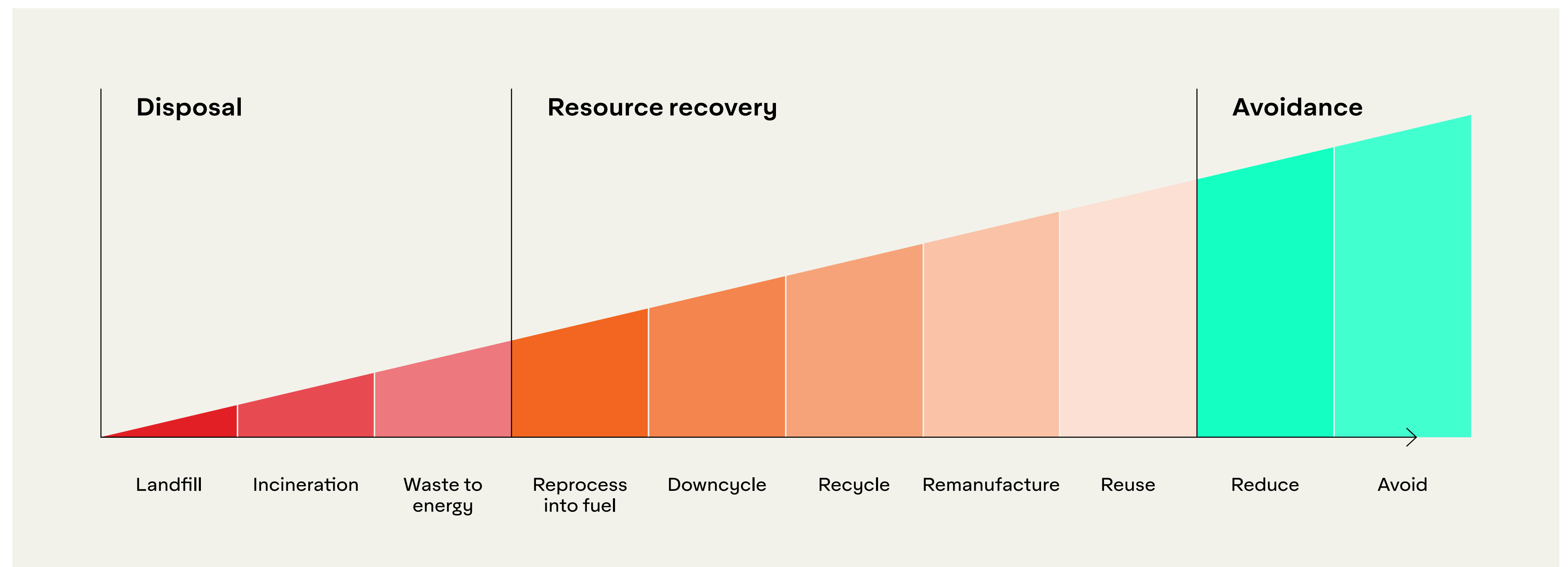

Downcycling

Packaging is recycled for lower grade applications

Example:

Food grade packaging fibers are recycled into industrial grade fibers

Recycling

Packaging is recycled for alternate applications

Example:

Food grade packaging fibers are recycled into non-food grade fibers

Remanufacturing

Packaging is recycled back into the same applications

Example:

Food grade packaging is remade into food grade packaging

What does it mean to be recyclable?

To be considered “recyclable”, a product has to be collected, sorted, processed, and applied – none of these processes can be missing.

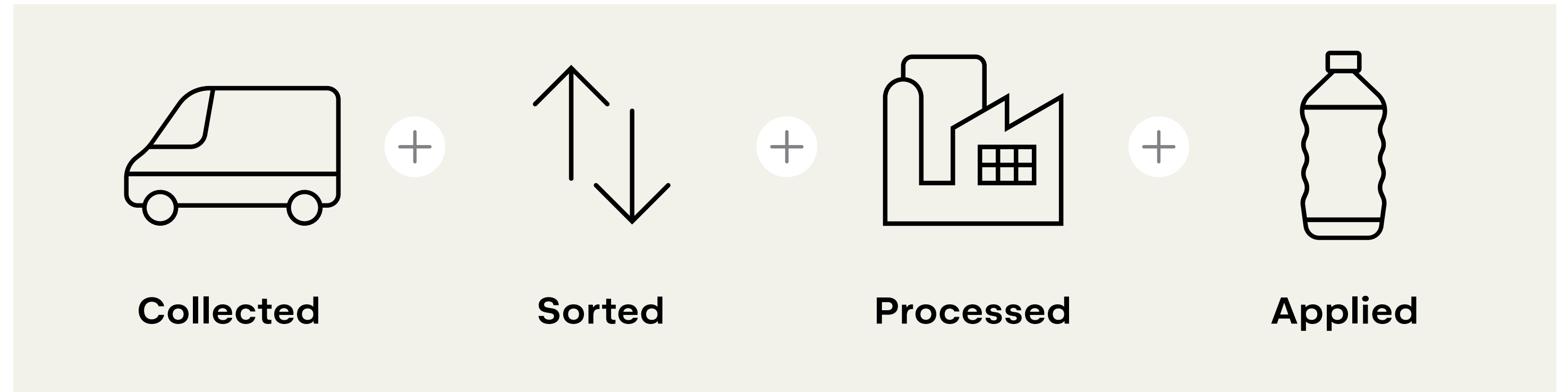

Ease of recycling various material types

	Paper and Cardboard	Glass	Metal Cans	PET	HDPE	PP	PS
Organised collection	●	●	●	●	●	●	●
Easy to separate	●	●	●	●	●	●	●
Availability of recyclers	●	●	●	●	●	●	●
Outlets for recycled materials	●	●	●	●	●	●	●
Food grade options for recyclates	●	●	●	●	●	●	●
Decoration impact on recyclability	●	●	●	●	●	●	●

Key: ● Technical challenges ● Some challenges ● Fully established

Main plastics types, applications and recycling potential

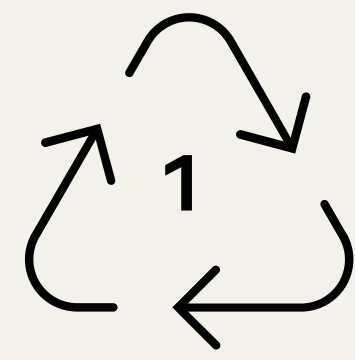

PET

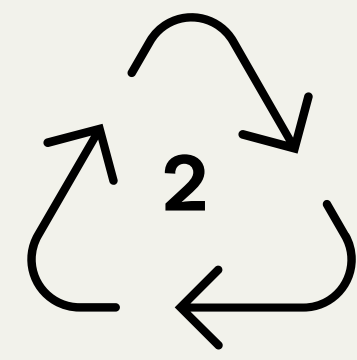

HDPE

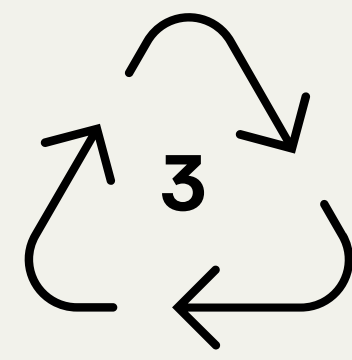

PVC

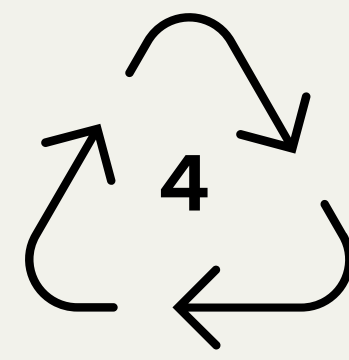

LDPE

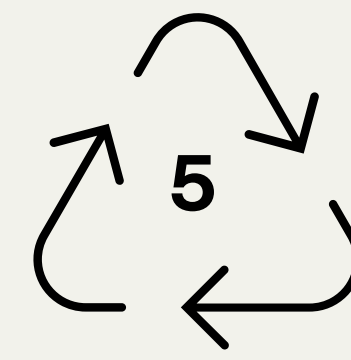

PP

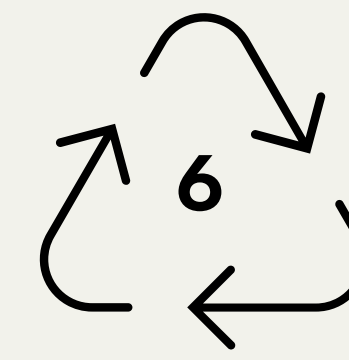

PS

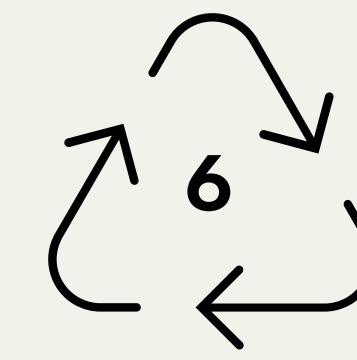

EPS

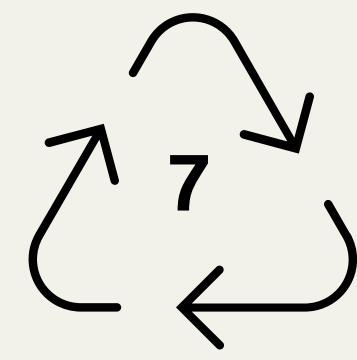

OTHER

Bottle to bottle

Water & soft drink bottles, salad domes, biscuit trays, salad dressing and peanut butter dressings

Bottle to bottle

Milk bottles/ jugs, freezer bags, dip tubs, shopping bags, ice cream containers, juice bottles, shampoo bottles, chemical & detergent

Limited options

Cosmetic containers, commercial cling wrap

Downcycled

Squeeze bottles, cling wrap, shrink wrap, rubbish/trash bags

Downcycled

Microwave dishes, ice cream tubs, potato chip bags, dip tubs

Limited options

CD cases, water station cups, plastic cutlery, imitation crystal glassware, video cases

Limited options

Foamed polystyrene hot drink cups, hamburger take-away clamshells, foamed meat trays, protective packaging for fragile items

Limited options



Water cooler bottles, flexible films, multi-material packaging

What is the difference between chemical and mechanical recycling?

Chemical recycling describes innovative technologies where plastic waste is converted into feedstock that can be used to create new plastic products. Because chemical recycling methods and output varies, its environmental and economic impact are still being evaluated by the industry.

Mechanical recycling is a method by which waste materials are recycled into secondary raw materials without changing its basic structure. The material passes extensive manual or automated mechanical sorting processes in specialised facilities, designed to separate the different material streams. After the cleaning and grinding processes, the material is recovered by remelting and re-granulating.

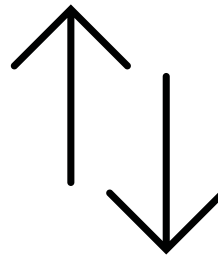
In terms of use, chemical recycling is a complementary solution to mechanical recycling, where the latter proves to be inefficient in case of difficult to recycle plastics, i.e. not properly sorted, multilayered, or heavily contaminated waste.

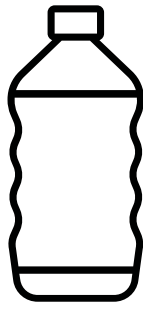
Recycling methods				
	Collected	Sorted	Processed	Applied
<p>Mechanical recycling The four steps are part of the recycling process. Depending on these steps the waste finds its route either to:</p>				
<p>Bottle-to-bottle recycling</p>		<p>Perfect sorting and no contamination. Preferred route for circularity in the future.</p>		<p>Remanufactured into the same object, i.e. bottles</p>
<p>General plastic recycling</p>		<p>Sorting is not perfect but can be used in alternate applications. This is commonly the existing route.</p>		<p>Recycled into other applications, i.e. clothing, outdoor furniture, automotive parts</p>
<p>Chemical recycling Mixed plastics to virgin material quality</p>		<p>Sorting still required. Mixed material can be recycled back to its base and make material equivalent to virgin standards.</p>		

Designing for Recyclability

Choosing the right label design for your product starts with understanding how the packaging protects your product, enhances consumer use, and enables a sustainable end-life.

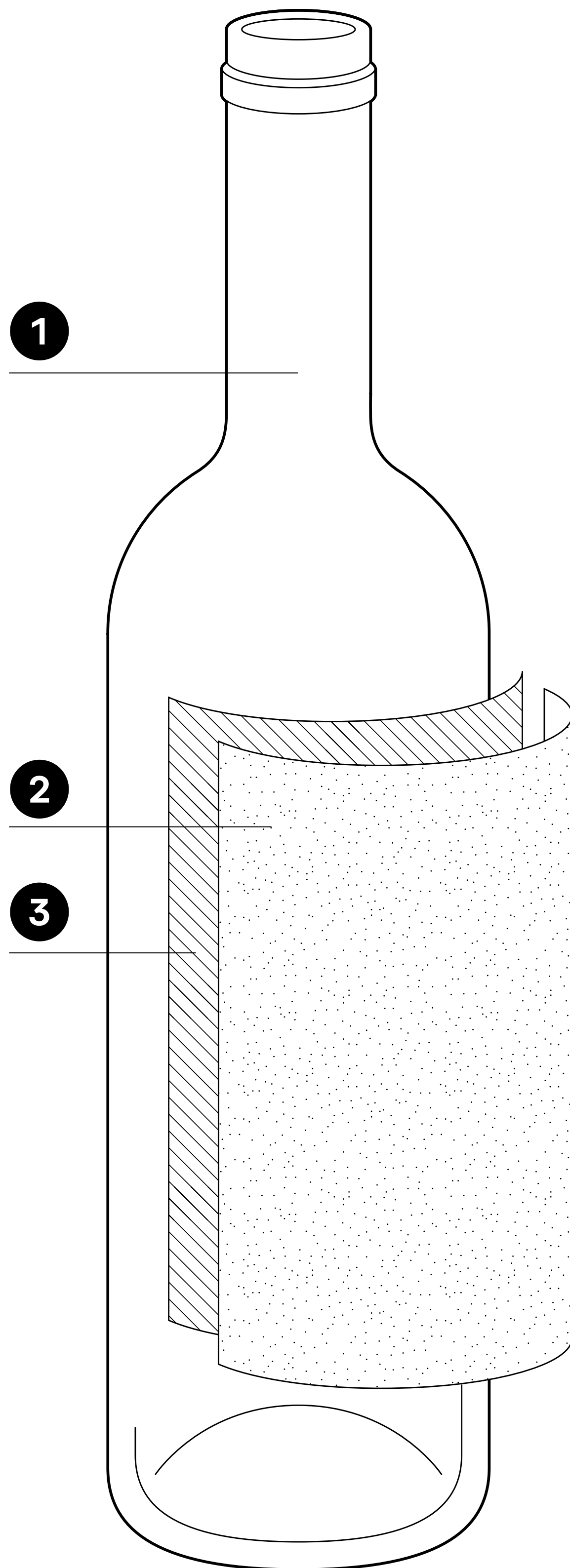

1 The container

Product

Choosing a container starts with the requirements of your product, including safe delivery of your product to the consumer, and meeting safety requirements and compliance regulations.

Use

Considering how consumers use your product is crucial for choosing the right container. Single-use products might do better in a plain, functional container, while products used daily may need a durable container that's more aesthetically pleasing to the consumer.

Afterlife

The lifecycle analysis of your product should include the packaging, as governments and consumers are looking to brands to create products that enable sustainability. If the container can't be recycled or reused, consumers may choose a product with packaging that can.

2 The label material

After the label material has met its compliance requirements, consider how its appearance will communicate the sustainability of your brand, product, and packaging. What material will convey your brand's sustainability focus best and look best on the shelf?

Ensuring the label can stand up to the use of the packaging is incredibly important for sustainability. If a label must be readable throughout the lifecycle of the product, a more durable material may be necessary. But for everyday products that consumers repeatedly buy and know how to use, perhaps a more minimal approach is appropriate.

When the product comes to the end of its life, how will the label material affect the recyclability of the packaging? For sustainable brands looking to make a meaningful waste reduction, a label that is recyclable or contains recycled content could be the right choice.

3 The adhesive

The combination of container, adhesive, and label can affect the legibility of the label, which could affect compliance, sustainability, and consumer use. If these are important to your product, you'll need to choose an adhesive that works with you.

Ensuring the label stays adhered for as long as necessary is an important consideration. A member of our team can help you choose an adhesive that works with your application and helps your brand meet your sustainability goals.

A label shouldn't hinder the recyclability or reusability of the packaging material. When a product has finished its consumer life and is ready for the waste (or recycle) stream, how will the adhesive affect its sustainability? Make sure you choose an adhesive technology like CleanFlake technology that enables the recyclability of your product.

Our sustainable solutions for each packaging substrate

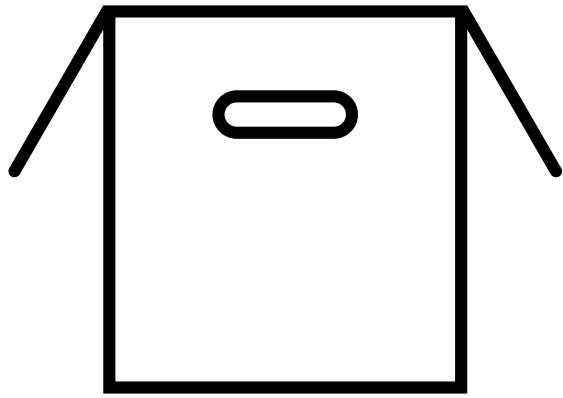
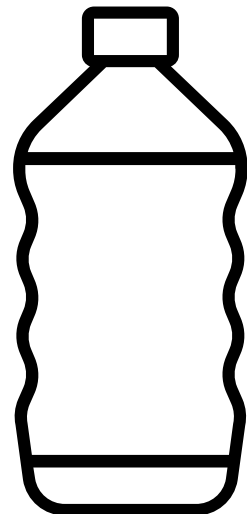
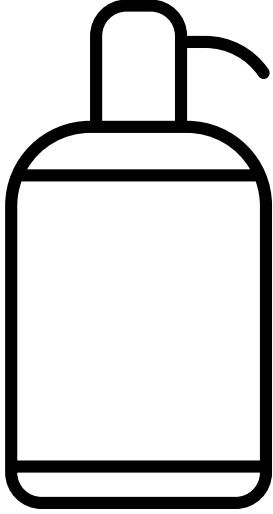
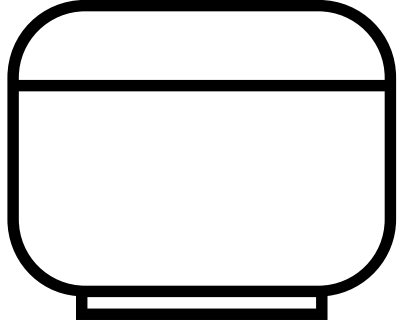
	Cardboard	PET	HDPE	PP
Packaging substrate				
Key end use segments	<ul style="list-style-type: none"> • Transport • Logistics 	<ul style="list-style-type: none"> • Beverage • Food • HPC 	<ul style="list-style-type: none"> • Food • Beverage • HPC 	<ul style="list-style-type: none"> • Dairy • HPC (minor)
Label types and technologies	<ul style="list-style-type: none"> • Paper DT (PSL) 	<ul style="list-style-type: none"> • PP (wrap around) • PP, Paper (PSL) • Sleeves 	<ul style="list-style-type: none"> • Paper (wet glue) • PE, MDO, paper (PSL) • Sleeves 	<ul style="list-style-type: none"> • Direct print • Paper (wet glue) • PP (PSL)
Label separation process	Repulping	Sink float	Sink float & air blow (bottle to bottle)*	Sink float & air blow
Current Avery Dennison solutions	Standard paper/ VI labels	CleanFlake™ technology	Monomaterial packaging (HDPE)	Monomaterial packaging (PP)

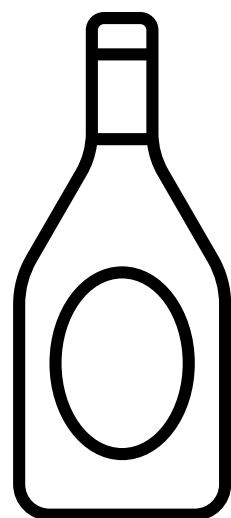
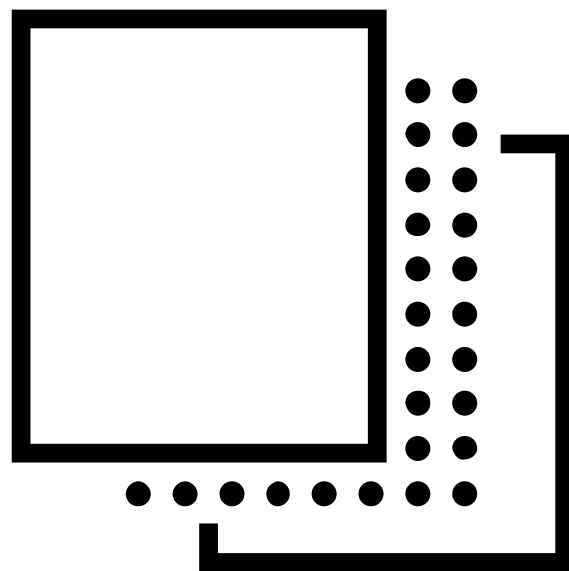
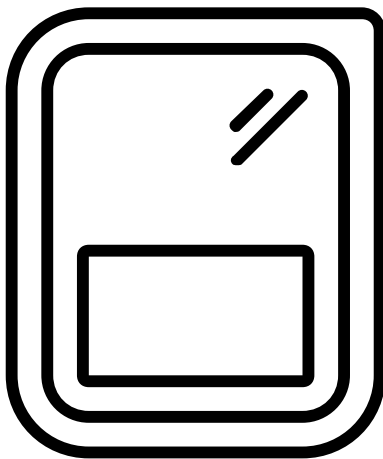
	PS	Glass	Compostable foil	Flexible packaging
Packaging substrate				
Key end use segments	<ul style="list-style-type: none"> • Food • Beverage 	<ul style="list-style-type: none"> • Beverage • Food 	<ul style="list-style-type: none"> • Food • Retail 	<ul style="list-style-type: none"> • HPC (wet wipes) • Food
Label types and technologies	<ul style="list-style-type: none"> • Direct print • Paper (wet glue) 	<ul style="list-style-type: none"> • Paper (wet glue) • Paper, PP (PSL) 	<ul style="list-style-type: none"> • Paper (PSL) 	<ul style="list-style-type: none"> • PP, PET, PE (PSL) • In some cases combination of PET and PP or PET and PE label layers
Label separation process	Brush off paper label	Washing, sorting (visual & mechanical)	Industrial composting	<p>No established recycling so far, CEFLEX advocating for monomaterial PE/PP</p> <p>In food PVDC-free OXYB solutions are preferred</p>
Current Avery Dennison solutions	Monomaterial packaging (PS)	Wash off/ glass recycling solutions	Monomaterial and compostable labels	<p>Monomaterial PE/PP labels</p> <p>PVDC-free OXYB PP labels</p>

Important information

Avery Dennison provides a broad range of solutions from Paper to Films, with many different adhesives available for different application needs.

Critical Substrates

Substances such as textiles, plasticised vinyls, apolar and rough surfaces.

Food Contact Status

For direct or indirect contact to food, adhesives must be certified to comply with international standards. The two most widely recognised standards are:

FDA (Food and Drug Administration) from the United States

- Indirect food contact (separated by a functional barrier) – FDA 21CFR175.105
- Direct contact to poultry, dry food, and processed, frozen, dried, or partially dehydrated fruits and vegetables – FDA 21CFR175.125 (a)
- Direct food contact to raw fruit and raw vegetables – FDA 21CFR175.125 (b)

BfR (Federal Institute for Risk Assessment) from Germany

- Direct contact with dry and moist non fatty foodstuffs for Plastic Dispersions (eg. Acrylic emulsion adhesives) – Bfr XIV
- Direct contact with dry and moist non fatty foodstuffs for Natural & Synthetic rubbers (eg Hot Melt Adhesives) – Bfr XXI

A number of Avery Dennison's adhesives are certified to these standards. Please contact your local Avery Dennison representative for an up-to-date listing of food-certified adhesives.

Quality Assurance

Avery Dennison self-adhesive materials are manufactured to high quality standards and are Certified to ISO 9001:2008.

Regulations and Specifications

Many Avery Dennison products have been tested to, and meet the various requirements of important regulations and international specifications such as toy labelling, labels for marine use, food labelling, industrial specifications, etc. Details can be made available upon request for each individual product.

Recommended Storage Conditions

Store at a temperature of 22°C +/- 2°C and a relative humidity of 50% +/- 5%.

- Original Packaging.
- Away from direct sunlight.
- Store reels of printed labels horizontally.
- Rotate stocks so that oldest material is used first.
- Ensure that winding tension of printed label reels is not too tight in order to prevent adhesive bleed.
- Repack partly-used reels of raw material or printed labels in their original packaging or identical packaging material.

Important Information

Important Notice

Information on physical and chemical characteristics is based upon tests we believe to be reliable. The values are intended only as a source of information and are given without guarantee and do not constitute a warranty. Purchasers should independently determine, prior to use, the suitability of any material for a specific purpose.

Warranty

Avery Dennison products are manufactured under careful quality control and are warranted to be free from defect in materials and workmanship. Any material shown to our satisfaction to be defective at the time of delivery will be compensated as per local country policy on the roll(s) returned. The manufacturer will not be responsible for claims beyond replacement of the material.

No sales person, representative or agent is authorised to give any guarantee, warranty or make any representation contrary to the foregoing.

All products described herein are sold subject to Avery Dennison's standard conditions of sale, a copy of which is available upon request.

Environmental Aspects

Avery Dennison is committed to protecting the environment and manufacturing safe products. We are actively involved in a continuous search for base materials and manufacturing technologies that have the least possible impact on the environment. For information on individual products or components please contact your Avery Dennison representative.

Disclaimer Information

Specific products must be used for the following applications – Hot Fill or Freshly Blow Molded Bottles; Blood Bags and products for Primary Food Contact.

Outdoor use of PVCs (due to plasticiser migration) and synthetic films when exposure to direct UV light can in no way be guaranteed. Check with Marketing on recommended life.

Wine Labels - The selection of suitable varnishes for white wine applications needs to be made in conjunction with your ink supplier and with the knowledge that uncoated paper stocks will exhibit higher moisture ingress versus alternative substrates.

Product Selection Considerations

As part of our commitment to improve and innovate, these selection considerations were written to guide you through the product selection process. Choosing the right product can be a challenge, but with Avery Dennison it's easy. Simply understand your requirements then call your local Avery Dennison representative.

1. Is the label to be permanent or removable?

- a) For removable labels ensure the substrate is strong enough to withstand label removal.
- b) Larger labels may require a stronger facestock to prevent tear on removal.
- c) A label is considered permanent if the bond to the substrate is impossible to remove without tearing the material.

2. What is the composition of the substrate?

- a) The composition of the substrate that the label will be applied to can have an effect on the ultimate strength of the bond that the label will form.
- b) On low surface energy materials, initial tack is the most important criteria. Adhesive levels will improve with longer dwell.

3. What is the texture of the substrate's surface?

- a) The texture of a substrate can have an impact on the formation adhesive.
- b) Textured materials do not allow 100% contact of the adhesive. Less contact means a smaller bonding area which will result in lower adhesion.
- c) Performance on heavily textured materials is improved with careful product selection.
- d) A more aggressive adhesive will maximize the adhesion at contact area.

4. What is the shape of the substrate?

- a) The shape of the substrate along with the size and stiffness of the label must be considered to ensure proper end-use performance. Curved surfaces (less than 25mm in diameter) will require an aggressive adhesive combined with a flexible facestock featuring little or no memory.
- b) Small labels or stiff facestocks may not adhere well on curved or irregular surfaces.

5. Is the application surface clean or contaminated?

- a) The cleanliness of the surface of the substrate when the label is applied will affect the ultimate adhesion of the label and the success of the application. Contamination from oil, grease, frost, dust, moisture and release agents are some causes of label failure.
- b) If contamination cannot be avoided, careful product selection can overcome the negative impact.

6. Are there any plasticisers present in the substrate?

- a) Plastics containing plasticisers (softeners) will degrade the adhesive bond strength and may render the label useless. Careful product selection can overcome the negative impact.

7. Are there any special application or exposure conditions that the label must withstand?

- a) Will the label be exposed to solvent/cleaning agents, large amounts of humidity or moisture, UV light or ozone?
- b) What is the application temperature of the label?
- c) Service Temperature - will the label be exposed to deep freeze conditions?

8. What are the printing, imprinting and conversion requirements?

- a) Most paper facestocks are suitable for all printing methods. Non-absorbent film facestocks require different considerations.
- b) When high quality process printing is required, careful selection of the facestock will be required.
- c) When imprinting is required, good resolution and smudge resistance is important.
- d) Corona treated films - effectiveness of the corona treatment reduces in time and can also be affected by abrasion or damage. To ensure optimum wettability and ink bond, additional in-line corona treatment is recommended for optimum ink key.
- e) All dies should be proofed to the construction.
- f) Complex shaped labels and square corners may limit the conversion speed.

Avery Dennison
Label and Packaging Materials Australia
4 Duigan Dr
Moorabbin Airport, VIC 3194
Sales: 1300 369 984

General Enquiries:
lpm.anz@ap.averydennison.com

Orders can be placed at:
aus.sales@ap.averydennison.com

label.averydennison.com

Avery Dennison
Label and Packaging Materials New Zealand
9 George Bourke Drive
Mount Wellington, AKL 1060
Sales: 09 573 0995

General Enquiries:
nzsales.anz@ap.averydennison.com

Orders can be placed at:
nzsales.anz@ap.averydennison.com

DISCLAIMER – All Avery Dennison statements, technical information and recommendations are based on tests believed to be reliable but do not constitute a guarantee or warranty. All Avery Dennison products are sold with the understanding that purchaser has independently determined the suitability of such products for its purposes. All Avery Dennison's products are sold subject to Avery Dennison's general terms and conditions of sale, see <http://terms.averydennison.com>. © 2022 Avery Dennison Corporation. All rights reserved. Avery Dennison and all other Avery Dennison brands, this publication, its contents and product names and codes are owned by Avery Dennison Corporation. All other brands and product names are trademarks of their respective owners. This publication must not be used, copied or reproduced in whole or in part of purposes other than marketing by Avery Dennison.

